

AEROMOB

ILLUSTRATED PARTS CATALOGUE



EQUIPMENT NAME: HARDMOB2.0 145D
PART NUMBER: AM-HDM-145D

AEROMOB

ILLUSTRATED PARTS CATALOGUE



Aeromob Equipamentos Aeronáuticos Ltda

CNPJ: 40.061.679/0001-43

Address: 990 Carlos Willy Boehm St.

Costa e Silva - Joinville - SC

ZIP code: 89218-325

Phone number: +55 47 4101- 2724 | +55 47 9 9937- 9077

Visit our website www.aeromobusa.com

Contact us for more information about spare parts and products.

INTRODUCTION

The Illustrated Parts Catalog (IPC) must be used to identify parts and component replacement request. The IPC should never be used as a component removal, installation and maintenance procedure. This catalog is used in conjunction with the Equipment Maintenance Manual (MM). The structure of chapters and details used in this IPC follow the applicable standards as Air Transport Association (ATA) SPEC 100 and iSPEC 2200.

The catalog features:

1. A list of chapters;
2. An isometric view of the equipment with emphasis on the set shown in the chapter;
3. An exploded view of each equipment set and its respective list of components;
4. The numbering of the pages is composed initially by the number of the chapter and followed by chapter page number.

PART DESIGNATION

AEROMOB parts are designated using the following code:

AM-HDM-135-S01

such that,

AM: AEROMOB

HDM: Represents the family of equipment

135: the equipment model

S01: represents the part-specific code.

On standard components purchased from third parties such as screws bearings, etc., the codes are varied, according to the necessary specification in each item. In some cases, manufacturers codes are also used.

AEROMOB special tools are designated with an "FM" prefix keeping then the identification code of the equipment to which it is applied.

AEROMOB

INTRODUCTION

PARTS AVAILABILITY

"YES" indicates the part is available as a separate replacement item.

"NO" indicates that the part is no longer available or is only available as part of a set.

ABBREVIATIONS

BICR - Bichromated
CL - Class
DISP - Parts availability
SS - Stainless steel
HS - Hexagon socket
WS - Worm shaft
TS - Top Shaft

GUARANTEE

AEROMOB applies the standard 1-year warranty on parts and components purchased from AEROMOB or an authorized dealer.

RETURNS

No unused parts may be returned to AEROMOB for credit if the parts show any indication of wear or damage, or if the cost of the individual part is less than \$25 (US). Parts returned within 30 days of purchase will be valued at a 20% restocking fee. no part may be returned after 30 days without AEROMOB's prior approval. Any parts approved for return after 30 days will be evaluated at a fee 50% restocking fee.

AEROMOB

INTRODUCTION

This document is copyrighted. The total or partial copy of the text, images or tables without the authorization of AEROMOB is expressly prohibited, subjecting the violator to the appropriate civil and criminal penalties.

AEROMOB

SUMMARY

CHAPTER 1 -	LEFT BODY	1-1
	BILL OF MATERIALS	1-2
	RIGHT BODY	1-4
	BILL OF MATERIALS	1-5
CHAPTER 2 -	LEFT BASE	2-1
	BILL OF MATERIALS	2-2
	RIGHT BASE	2-3
	BILL OF MATERIALS	2-4
CHAPTER 3 -	WHEEL	3-1
	BILL OF MATERIALS	3-2
CHAPTER 4 -	LEFT LEVER BAR	4-1
	BILL OF MATERIALS	4-2
	RIGHT LEVER BAR	4-3
	BILL OF MATERIALS	4-4
CHAPTER 5 -	LEFT RATCHET HANDLE	5-1
	BILL OF MATERIALS	5-2
	RIGHT RATCHET HANDLE	5-3
	BILL OF MATERIALS	5-4
CHAPTER 6 -	LEFT GRAB	6-1
	BILL OF MATERIALS	6-2
	RIGHT GRAB	6-3
	BILL OF MATERIALS	6-4

REVISION

Revision Number	Date
Revision 1	23/05/2023
Revision 2	20/06/2023
Revision 3	10/07/2023
Revision 4	25/10/2023

To access the updated version of this document, point your device at the QR CODE below.



www.aeromob.com.br/support-am-hdm-145d-k01

AEROMOB

CHAPTER 1 - LEFT BODY

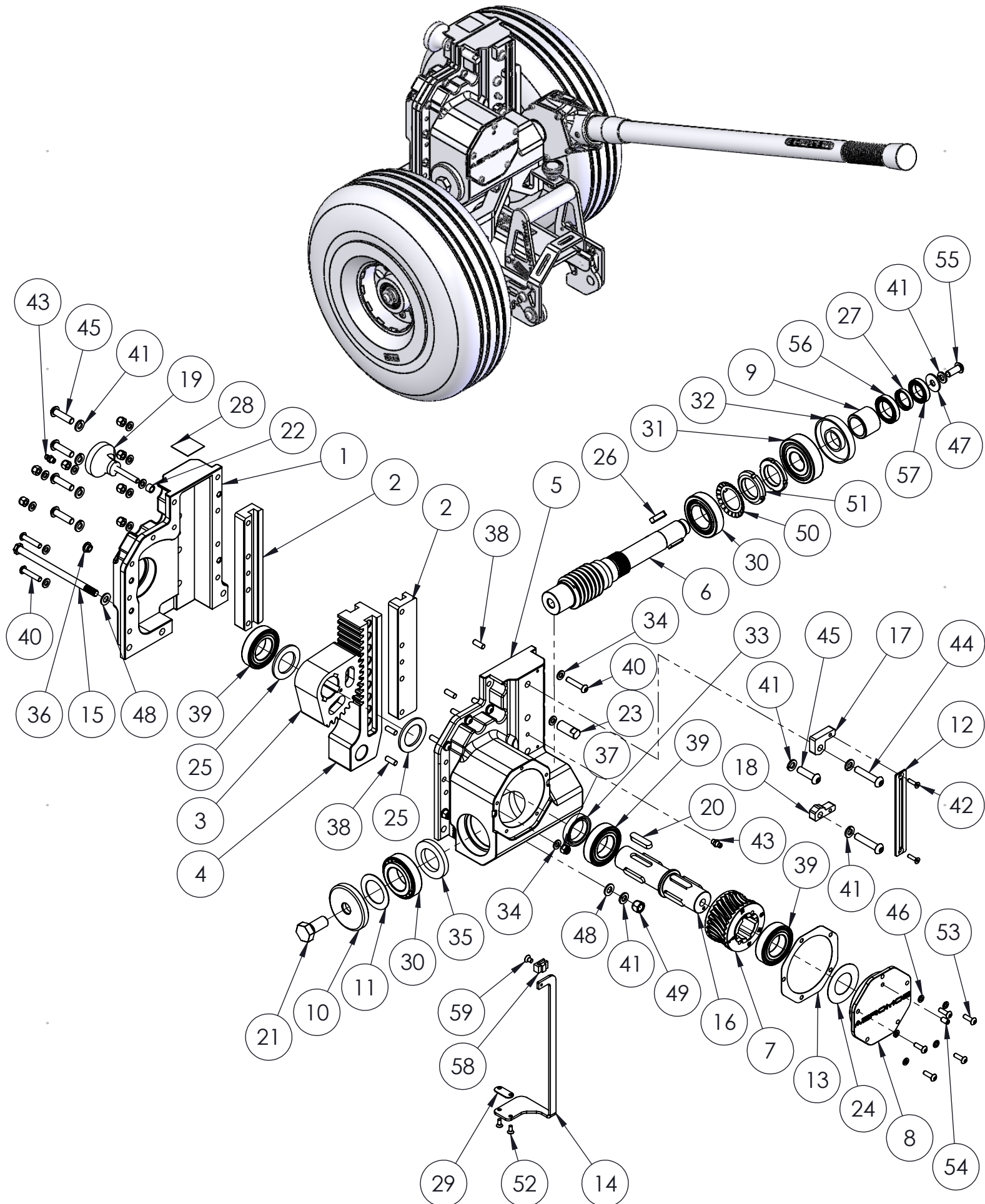

AEROMOB

POS	ACTIVE PN	DESCRIPTION	QTY IN THIS DRAWING	QTY EQUIPMENT	OLD PN	APPLICABLE TO SN	AVAIL
1	AM-HDM-145D-001	LEFT COVER	1	1	---	ALL	---
2	AM-HDM-145D-002	GEAR RACK GUIDE	2	4	---	ALL	---
3	AM-HDM-145D-003	PINION 2.0	1	2	---	ALL	---
4	AM-HDM-145D-004	GEAR RACK 2.0	1	2	---	ALL	---
5	AM-HDM-145D-005	LEFT BLOCK	1	2	---	ALL	---
6	AM-HDM-145D-006	LEFT WORM SHAFT	1	1	---	ALL	---
7	AM-HDM-145D-007	LEFT WORM GEAR	1	1	---	ALL	---
8	AM-HDM-145D-008	FRONTAL COVER	1	2	---	ALL	---
9	AM-HDM-145D-009	SPACER BUSHING	1	2	---	ALL	---
10	AM-HDM-145D-010	WORM SHAFT WASHER	1	2	---	ALL	---
11	AM-HDM-145D-014	WS RETAINING WASHER	1	2	---	ALL	---
12	AM-HDM-145D-124	HEIGHT DISPLAY	1	1	---	ALL	---
13	AM-HDM-145D-037	FRONT COVER GASKET	1	2	---	ALL	---
14	AM-HDM-145D-127	LEFT ARROW	1	1	---	ALL	---
15	AM-HDM-145D-051	SS SCREW 8MM	1	2	---	ALL	---
16	AM-HDM-145D-063	TOP SHAFT	1	2	---	ALL	---
17	AM-HDM-145D-117	UPPER STOPPER	1	2	---	ALL	---
18	AM-HDM-145D-125	LOWER STOPPER	1	2	---	ALL	---
19	AM-HDM-145D-075	RUBBER DAMPER	1	2	---	ALL	---
20	AM-HDM-145D-076	TOP SHAFT KEY	7	14	---	ALL	---
21	AM-HDM-145D-078	SPECIAL SCREW	1	1	---	ALL	---
22	AM-HDM-145D-085	SPACER	1	2	---	ALL	---
23	AM-HDM-145D-089	SPECIAL NUT 1/4"	1	2	---	ALL	---
24	AM-HDM-145D-094	BEARING HOUSE GASKET	1	2	---	ALL	---
25	AM-HDM-145D-100	TS RETAINING WASHER	2	4	---	ALL	---
26	CH 6X6X25	KEY 6 x 6 x 25	2	4	---	ALL	---
27	AM-HDM-145D-017	RATCHER HANDLE SPACER	1	2	---	ALL	---
28	AM-HDM-145D-114	QR CODE MANUAL	1	2	---	ALL	---
29	AM-HDM-145D-118	ARROW SPACER	1	2	---	ALL	---
30	ROL 320/32X	BEARING SKF 320/32 X	2	4	---	TODOS	---
31	ROL W 6305-2RS1	BEARING 6305-2RS	1	2	---	TODOS	---

POS	ACTIVE PN	DESCRIPTION	QTY IN THIS DRAWING	QTY EQUIPMENT	OLD PN	APPLICABLE TO SN	AVAIL
32	RET-BRG-6244	WHEEL SEAL 6244 BRG SABÓ	1	2	---	ALL	---
33	RET-BRG-01667	WHEEL SEAL 01667 Ø30xØ42x8mm	1	2	---	ALL	---
34	INOX DIN125 M6	SS - FLAT WASHER M6	20	40	---	ALL	---
35	RET-BRG-2699	WHEEL SEAL 02699 BRG SABÓ	1	2	---	ALL	---
36	TAMP10	RUBBER END CAP	1	2	---	ALL	---
37	INOX DIN982 M6	SS - SELF-LOCKING NUT M6	9	18	---	ALL	---
38	DIN6325 6X16	GUIDE PIN DIN 6325 Ø6 x 16	4	8	---	ALL	---
39	ROL W 6006-2RS1	BEARING W 6006 - 2RS1	3	6	---	ALL	---
40	INOX DIN7380 M6X30	SS - HS BUTTON H SCREW M6 x 30	9	18	---	ALL	---
41	INOX DIN127 M8	SS - SPLIT LOCK WASHER M8	9	34	---	ALL	---
42	INOX DIN7991 M4X16	SS - HS COUNTERSUNK HC SCREW M4X16	2	4	---	ALL	---
43	INOX GRAXEIRO M6	SS - STRAIGHT GREASE NIPLE M6	2	4	---	ALL	---
44	INOX DIN 7380 M8X40	SS - HS BUTTON H SCREW M8X40	2	4	---	ALL	---
45	INOX DIN7380 M8X30	SS - HS BUTTON H SCREW M8X30	5	14	---	ALL	---
46	INOX DIN127 M5	SS - SPLIT LOCK WASHER M5	5	10	---	ALL	---
47	INOX DIN9021 M8	SS - LARGE FLAT WASHER M8	1	10	---	ALL	---
48	INOX DIN125 M8	SS - FLAT WASHER M8	2	24	---	ALL	---
49	INOX DIN982 M8	SS - SELF-LOCKING NUT M8	1	12	---	ALL	---
50	DIN5406 MB6	SS - INTERNAL TOOTH LOCK WASHER MB6	1	2	---	ALL	---
51	DIN981 KM6	SS - KM6 LOCK NUT	2	4	---	ALL	---
52	INOX DIN7991 M4X10	SS - HS COUNTERSUNK HC SCREW M4X10	2	4	---	ALL	---
53	INOX DIN7380 M5X16	SS - HS BUTTON H SCREW M8X30	5	18	---	ALL	---
54	INOX DIN913 M6X12	SS - SOCKET SET SCREW M6X12	1	2	---	ALL	---
55	INOX DIN7380 M8X20	SS - HS BUTTON H SCREW M8X20	1	2	---	ALL	---
56	ROL W61805-2RZ	BEARING W 61805 2RZ	1	2	---	ALL	---
57	ROL W61804-2RS	BEARING 61804 2RS	1	2	---	ALL	---
58	AM-HDM-145D-131	TAG BASE	1	2	---	ALL	---
59	INOX DIN7991 M5X8	SS - HS COUNTERSUNK HC SCREW M4 x 10	1	2	---	ALL	---

CHAPTER 1 - RIGHT BODY

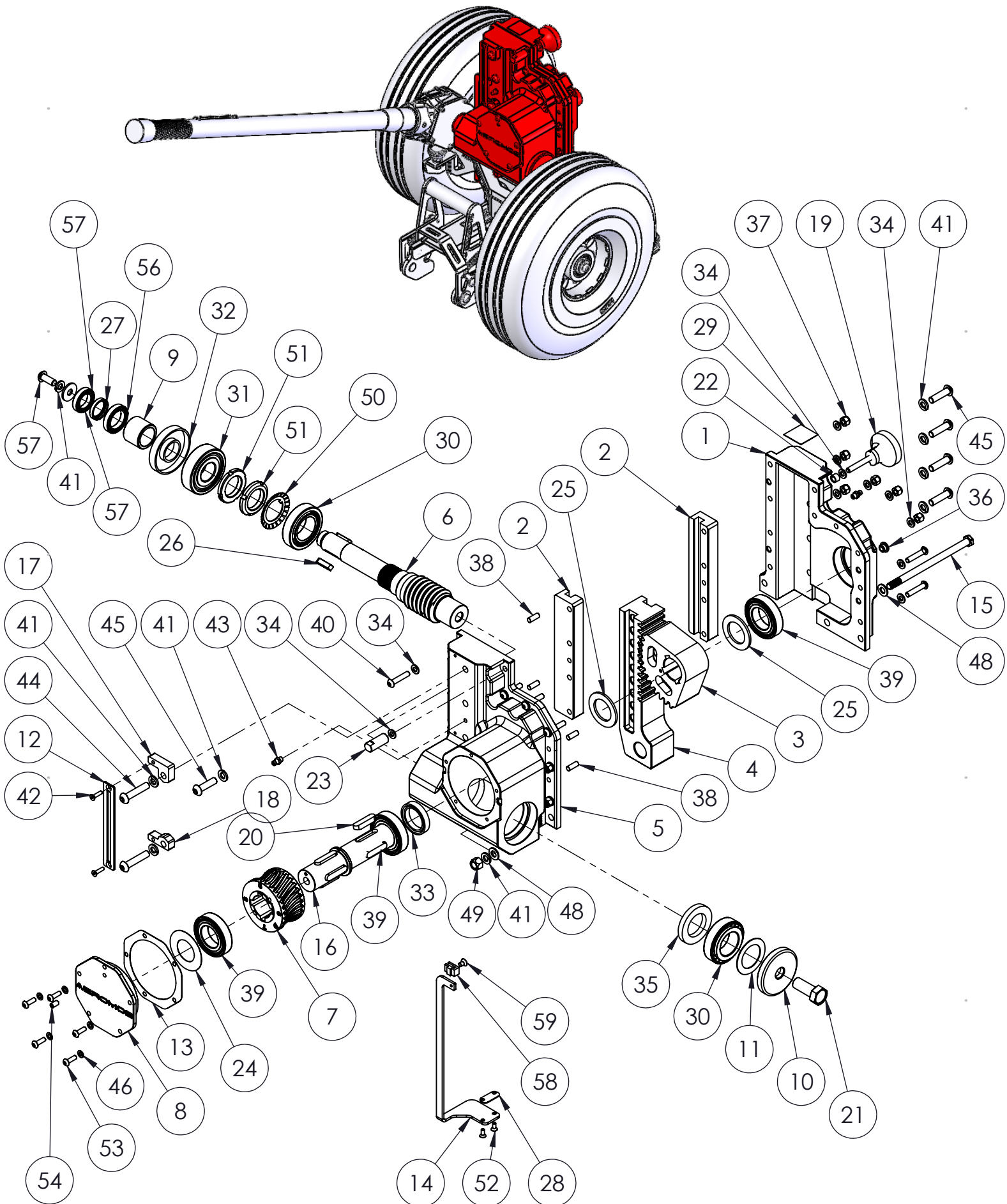

AEROMOB

POS	ACTIVE PN	DESCRIPTION	QTY IN THIS DRAWING	QTY EQUIPMENT	OLD PN	APPLICABLE TO SN	AVAIL
1	AM-HDM-145D-052	RIGHT COVER	1	1	---	ALL	---
2	AM-HDM-145D-002	GEAR RACK GUIDE	2	4	---	ALL	---
3	AM-HDM-145D-003	PINION 2.0	1	2	---	ALL	---
4	AM-HDM-145D-004	GEAR RACK 2.0	1	2	---	ALL	---
5	AM-HDM-145D-053	RIGHT BLOCK	1	2	---	ALL	---
6	AM-HDM-145D-096	RIGHT WORM SHAFT	1	1	---	ALL	---
7	AM-HDM-145D-097	RIGHT WORM GEAR	1	1	---	ALL	---
8	AM-HDM-145D-008	FRONTAL COVER	1	2	---	ALL	---
9	AM-HDM-145D-009	SPACER BUSHING	1	2	---	ALL	---
10	AM-HDM-145D-010	WORM SHAFT WASHER	1	2	---	ALL	---
11	AM-HDM-145D-014	WS RETAINING WASHER	1	2	---	ALL	---
12	AM-HDM-145D-124	HEIGHT DISPLAY	1	1	---	ALL	---
13	AM-HDM-145D-037	FRONT COVER GASKET	1	2	---	ALL	---
14	AM-HDM-145D-126	RIGHT ARROW	1	1	---	ALL	---
15	AM-HDM-145D-051	SS SCREW 8MM	1	2	---	ALL	---
16	AM-HDM-145D-063	TOP SHAFT	1	2	---	ALL	---
17	AM-HDM-145D-117	UPPER STOPPER	1	2	---	ALL	---
18	AM-HDM-145D-125	LOWER STOPPER	1	2	---	ALL	---
19	AM-HDM-145D-075	RUBBER DAMPER	1	2	---	ALL	---
20	AM-HDM-145D-076	TOP SHAFT KEY	7	14	---	ALL	---
21	DIN933 M14X35 CL12.9	BICR - HEX HEAD CAP SCREW M14 x 35 CL 12.9	1	1	---	ALL	---
22	AM-HDM-145D-085	SPACER	1	2	---	ALL	---
23	AM-HDM-145D-089	SPECIAL NUT 1/4"	1	2	---	ALL	---
24	AM-HDM-145D-094	BEARING HOUSE GASKET	1	2	---	ALL	---
25	AM-HDM-145D-100	TS RETAINING WASHER	2	4	---	ALL	---
26	CH 6X6X25	KEY 6 x 6 x 25	2	4	---	ALL	---
27	AM-HDM-145D-017	RATCHER HANDLE SPACER	1	2	---	ALL	---
28	AM-HDM-145D-118	ARROW SPACER	1	2	---	ALL	---
29	AM-HDM-145D-114	QR CODE MANUAL	1	2	---	ALL	---
30	ROL 320/32X	BEARING SKF 320/32 X	2	4	---	ALL	---
31	ROL W 6305-2RS1	BEARING 6305-2RS	1	2	---	ALL	---

POS	ACTIVE PN	DESCRIPTION	QTY IN THIS DRAWING	QTY EQUIPMENT	OLD PN	APPLICABLE TO SN	AVAIL
32	RET-BRG-6244	WHEEL SEAL 6244 BRG SABO	1	2	---	ALL	---
33	RET-BRG-01667	WHEEL SEAL 01667 BRG SABO	1	2	---	ALL	---
34	INOX DIN125 M6	SS - FLAT WASHER M6	20	40	---	ALL	---
35	RET-BRG-2699	WHEEL SEAL 02699 BRG	1	2	---	ALL	---
36	TAMP10	RUBBER END CAP	1	2	---	ALL	---
37	INOX DIN982 M6	SS - SELF-LOCKING NUT M6	9	18	---	ALL	---
38	DIN6325 6X16	GUIDE PIN DIN 6325 Ø6X16	4	8	---	ALL	---
39	ROL W 6006-2RS1	BEARING W 6006 - 2RS1	3	6	---	ALL	---
40	INOX DIN7380 M6X30	SS - HS BUTTON H SCREW M6 x 30	9	18	---	ALL	---
41	INOX DIN127 M8	SS - SPLIT LOCK WASHER M8	9	34	---	ALL	---
42	INOX DIN7991 M4X16	SS - HS COUNTERSUNK HC SCREW M4X16	2	4	---	ALL	---
43	INOX GRAXEIRO M6	SS - STRAIGHT GREASE NIPLE M6	2	4	---	ALL	---
44	INOX DIN 7380 M8X40	SS - HS BUTTON H SCREW M8X40	2	4	---	ALL	---
45	INOX DIN7380 M8X30	SS - HS BUTTON H SCREW M8X30	5	14	---	ALL	---
46	INOX DIN127 M5	SS - SPLIT LOCK WASHER M5	5	10	---	ALL	---
47	INOX DIN9021 M8	SS - LARGE FLAT WASHER M8	1	10	---	ALL	---
48	INOX DIN125 M8	SS - FLAT WASHER M8	2	24	---	ALL	---
49	INOX DIN982 M8	SS - HEX NUT M8	1	12	---	ALL	---
50	DIN5406 MB6	SS - INTERNAL TOOTH LOCK WASHER MB6	1	2	---	ALL	---
51	DIN981 KM6	SS - KM6 LOCK NUT	2	4	---	ALL	---
52	INOX DIN7991 M4X10	SS - HS COUNTERSUNK HC SCREW M4X10	2	4	---	ALL	---
53	INOX DIN7380 M5X16	SS - HS BUTTON H SCREW M5X16	5	18	---	ALL	---
54	INOX DIN913 M6X12	SS - SOCKET SET SCREW M6X12	1	2	---	ALL	---
57	INOX DIN7380 M8X20	SS - HS BUTTON H SCREW M8X20	1	2	---	ALL	---
56	ROL W61805-2RZ	BEARING W 61805 2RZ	1	2	---	ALL	---
57	ROL W61804-2RS	BEARING 61804 2RS	1	2	---	ALL	---
58	AM-HDM-145D-131	TAG BASE	1	2	---	ALL	---
59	INOX DIN7991 M5X8	SS - HS COUNTERSUNK HC SCREW M4 x 10	1	2	---	ALL	---

CHAPTER 2 - LEFT BASE

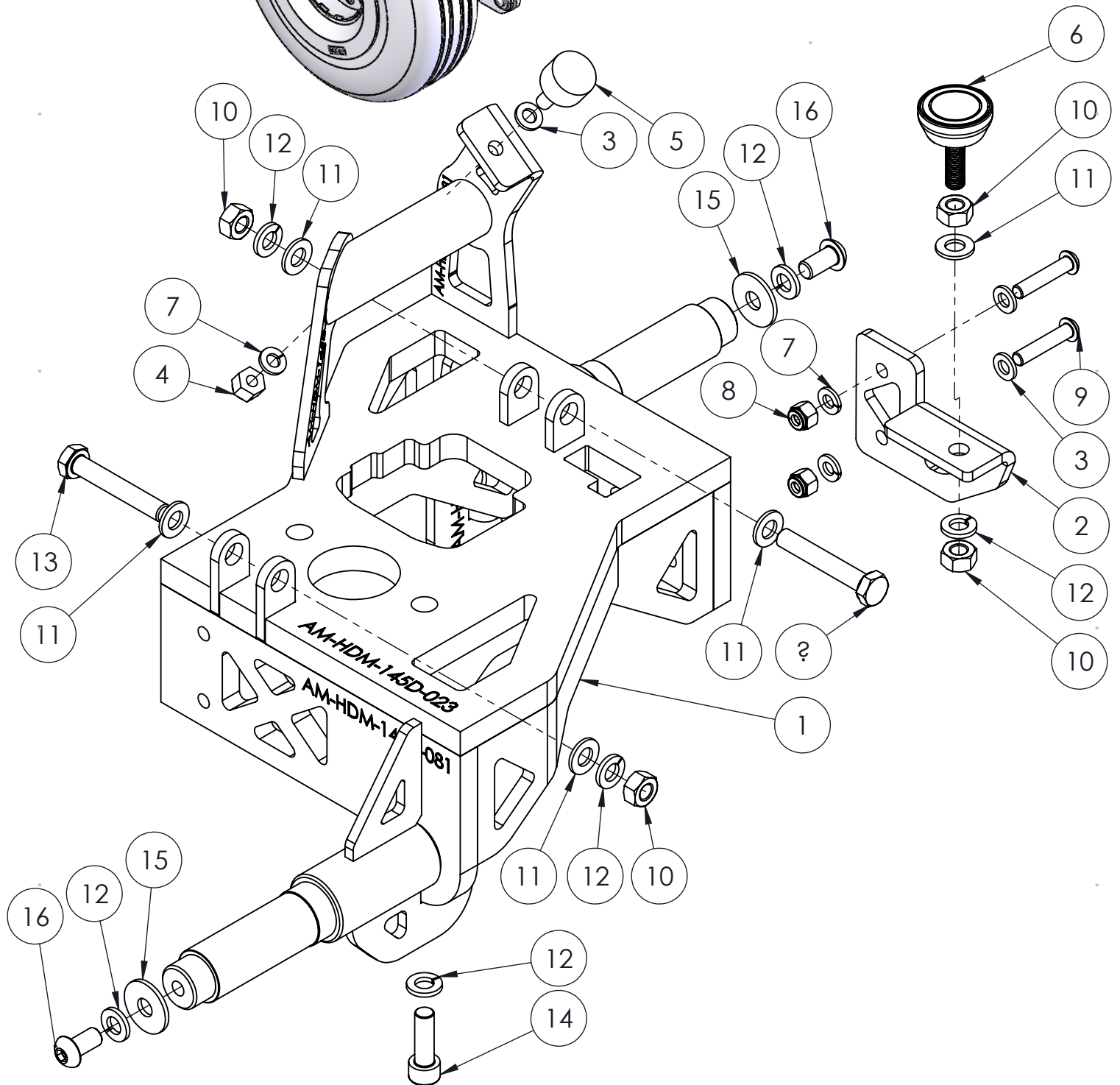
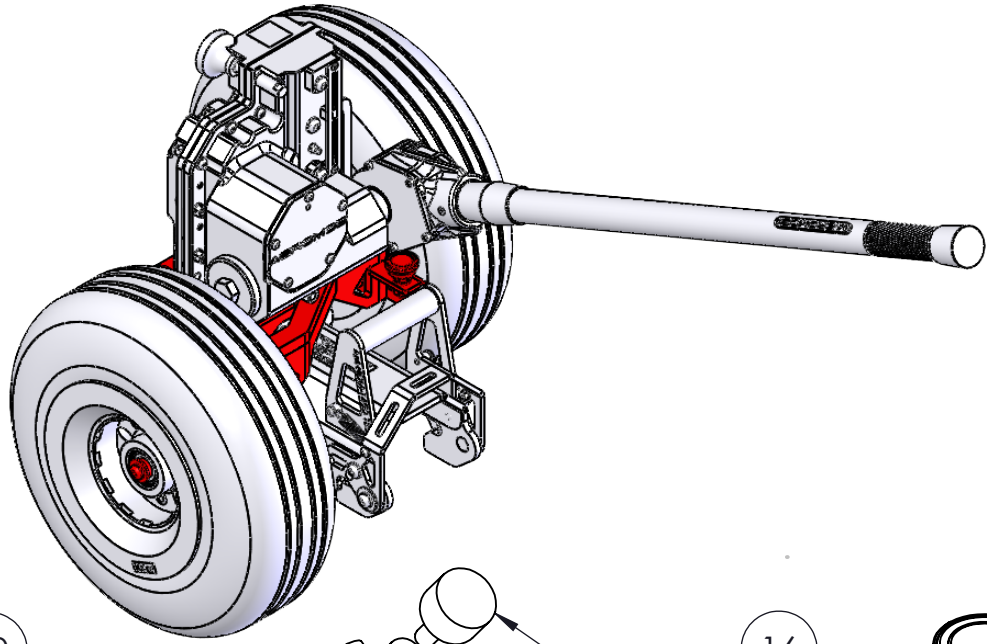

AEROMOB

POS	ACTIVE PN	DESCRIPTION	QTY IN THIS DRAWING	QTY EQUIPMENT	OLD PN	APPLICABLE TO SN	AVAIL
1	AM-HDM-145D-S02	LEFT BASE 145D	1	1	---	ALL	---
2	AM-HDM-145D-044	LEFT STOPPER	1	1	---	ALL	---
3	INOX DIN125 M6	SS - FLAT WASHER M6	3	46	---	ALL	---
4	INOX DIN982 1/4	SS - SELF-LOCKING NUT 1/4	1	22	---	ALL	---
5	BAT AB 1/4	RUBBER BUMPER 1/4	1	2	---	ALL	---
6	PENIV M8X27	LEVELER M8 X27 - PN 3012	1	2	---	ALL	---
7	INOX DIN127 M6	SS - SPLIT LOCK WASHER M6	3	4	---	ALL	---
8	INOX DIN982 M6	SS - SELF-LOCKING NUT M6	2	22	---	ALL	---
9	INOX DIN7380 M6X30	SS - HS BUTTON H SCREW M6 x 30	2	22	---	ALL	---
10	INOX DIN934 M8	SS - HEX NUT M8	4	12	---	ALL	---
11	INOX DIN125 M8	SS - FLAT WASHER M8	5	24	---	ALL	---
12	INOX DIN127 M8	SS - SPLIT LOCK WASHER M8	6	34	---	ALL	---
13	INOX DIN933 M8X50 RP	SS - HEX HEAD CAP SCREW M8 x 50 PT	2	4	---	ALL	---
14	INOX DIN912 M8X25	SS - HS H CAP SCREW M8 x 25	1	4	---	ALL	---
15	INOX DIN9021 M8	SS - LARGE FLAT WASHER M8	2	4	---	ALL	---
16	DIN7380 M8X16	SS - HS BUTTON H SCREW M6 X 30	2	4	---	ALL	---

CHAPTER 2 - RIGHT BASE

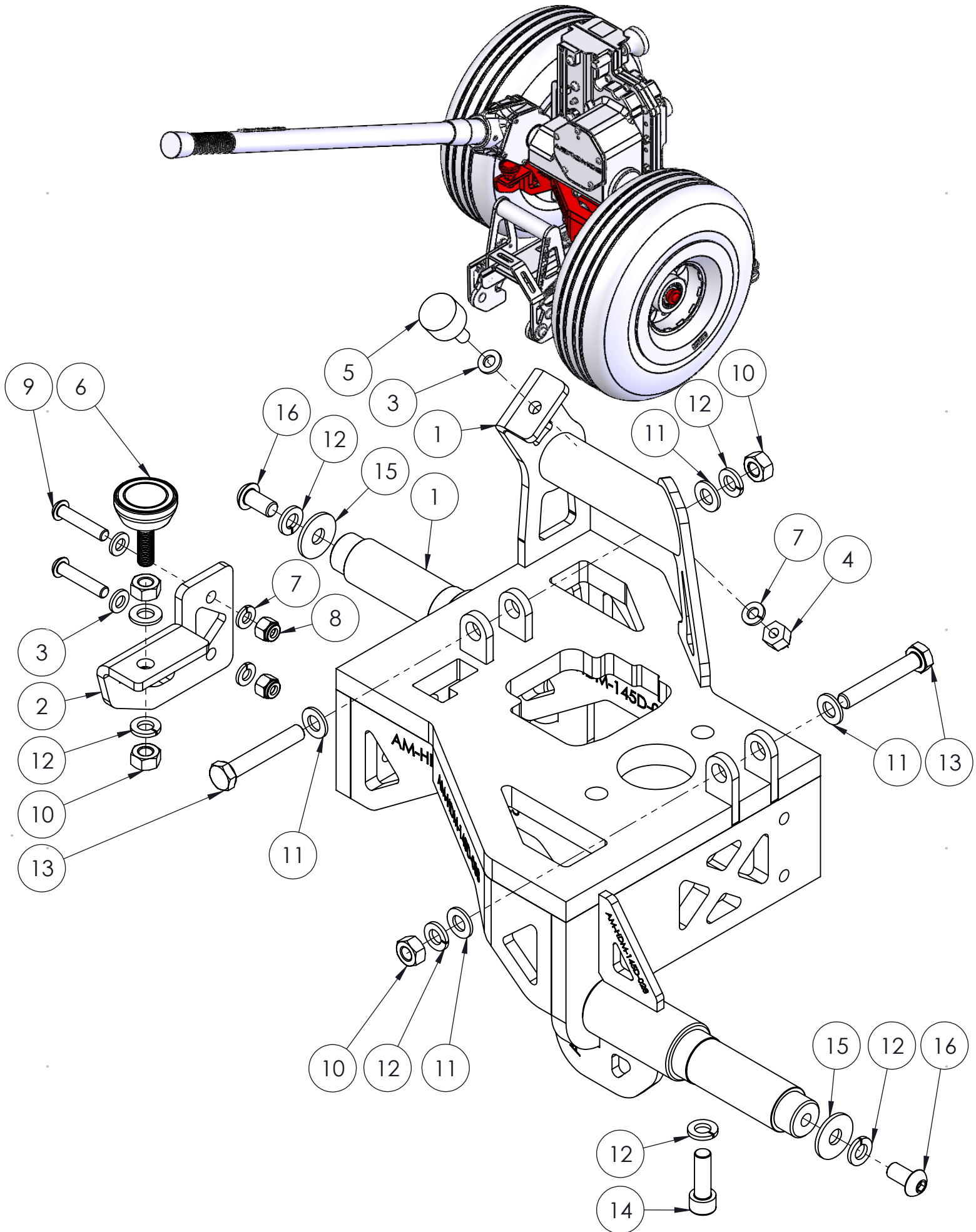

POS	ACTIVE PN	DESCRIPTION	QTY IN THIS DRAWING	QTY EQUIPMENT	OLD PN	APPLICABLE TO SN	AVAIL
1	AM-HDM-145D-S05	RIGHT BASE 145D	1	1	---	ALL	---
2	AM-HDM-145D-061	RIGHT STOPPER	1	1	---	ALL	---
3	INOX DIN125 M6	SS - FLAT WASHER M6	3	46	---	ALL	---
4	INOX DIN982 1/4	SS - SELF-LOCKING NUT 1/4 POL	1	22	---	ALL	---
5	BAT AB 1/4	RUBBER BUMPER 1/4	1	2	---	ALL	---
6	PENIV M8X27	LEVELER M8 X27 - PN 3012	1	2	---	ALL	---
7	INOX DIN127 M6	SS - SPLIT LOCK WASHER M6	3	4	---	ALL	---
8	INOX DIN982 M6	SS - SELF-LOCKING NUT M6	2	22	---	ALL	---
9	INOX DIN7380 M6X30	SS - HS BUTTON H SCREW M6 x 30	2	22	---	ALL	---
10	INOX DIN934 M8	SS - HEX NUT M8	4	12	---	ALL	---
11	INOX DIN125 M8	SS - FLAT WASHER M8	5	24	---	ALL	---
12	INOX DIN127 M8	SS - SPLIT LOCK WASHER M8	6	34	---	ALL	---
13	INOX DIN933 M8X50 RP	SS -HEX HEAD CAP SCREW M8 x 50 PT	2	4	---	ALL	---
14	INOX DIN912 M8X25	SS - HS H CAP SCREW M8 x 25	1	4	---	ALL	---
15	INOX DIN9021 M8	SS - LARGE FLAT WASHER M8	2	4	---	ALL	---
16	DIN7380 M8X16	SS - HS BUTTON H SCREW M8 x 16	2	4	---	ALL	---

CHAPTER 3 - WHEEL

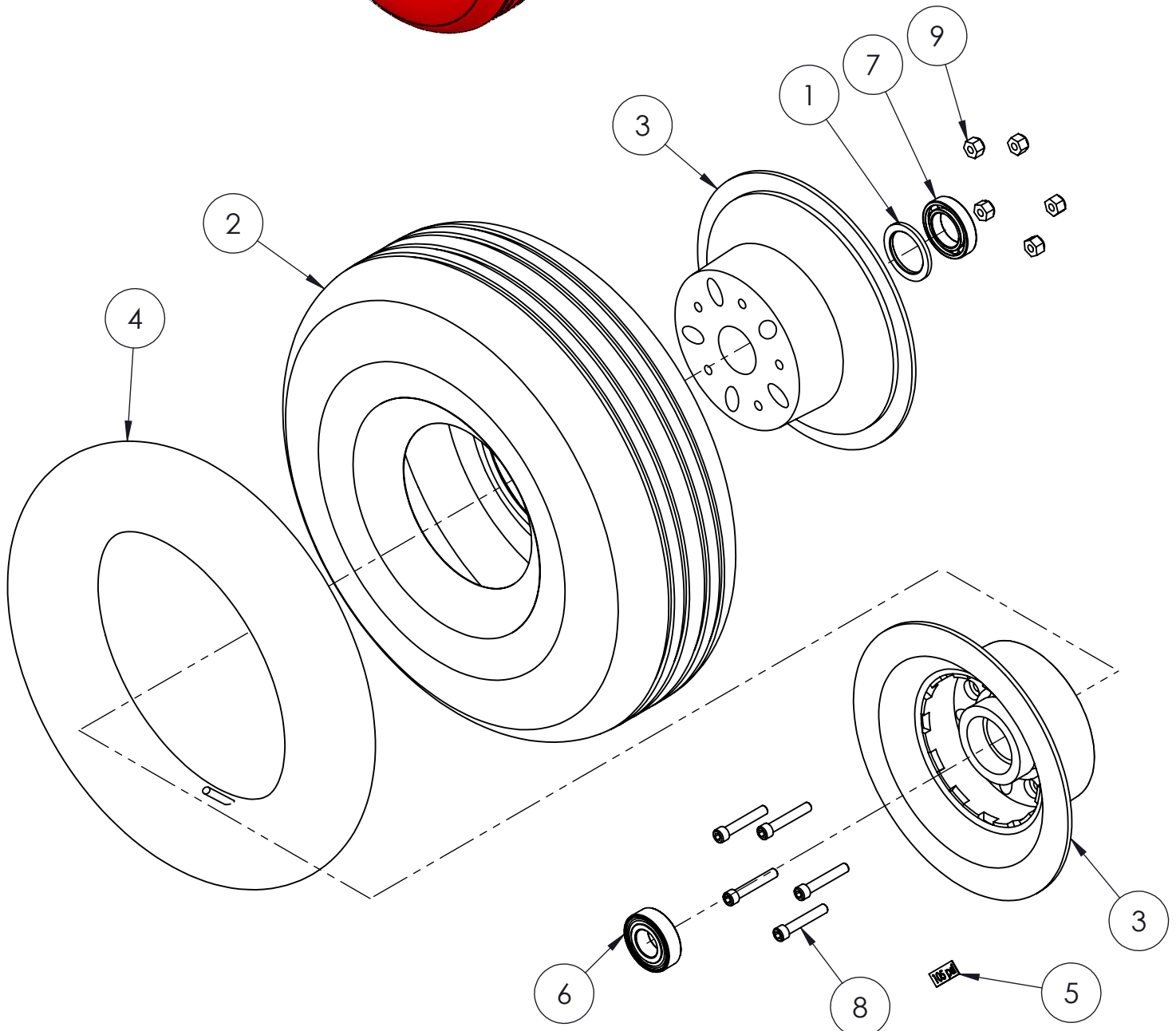
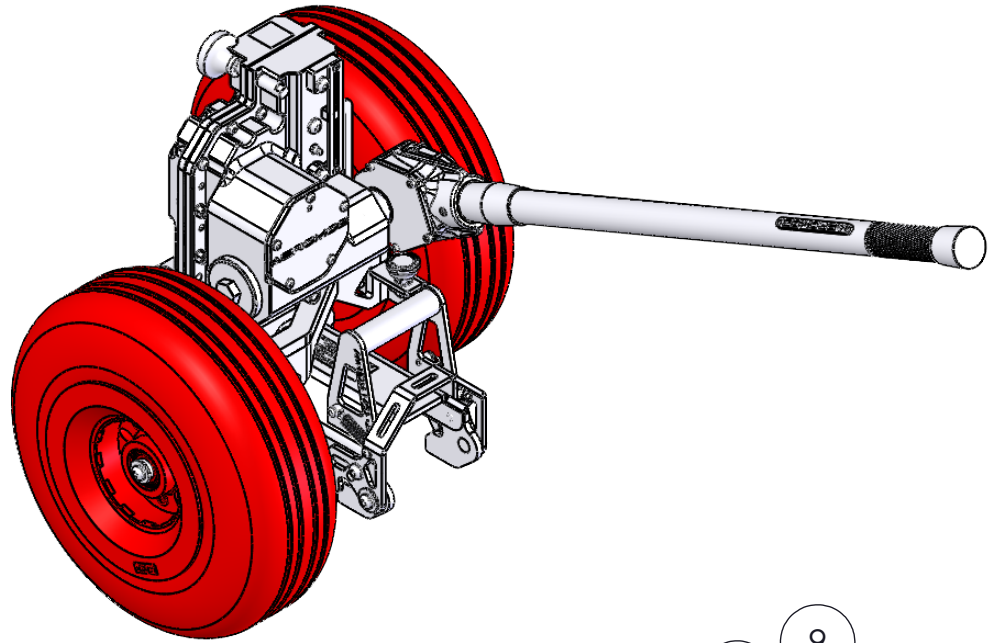

POS	ACTIVE PN	DESCRIPTION	QTY IN THIS DRAWING	QTY EQUIPMENT	OLD PN	APPLICABLE TO SN	AVAIL
1	AM-HDM-145D-093	SPACER WASHER	1	4	---	ALL	---
2	PNEU13.5/500/5	TIRE IM3 13,5 / 500 / 5	1	4	---	ALL	---
3	ARO5	WHEEL 5"	2	4	---	ALL	---
4	CA500.5	AIR CHAMBER - 500.5 IM3	1	4	---	ALL	---
5	AM-PLQ-005	CALIBRATION TAG 5 PSI	1	4	---	ALL	---
6	ROLW60042RS1	BEARING W 6004-2RS1	1	4	---	ALL	---
7	ROL 6905-ZZ	BEARING 6905 ZZ	1	4	---	ALL	---
8	ASMEB183 1/4X1.1/2	BICR - HS H CAP SCREW 1/4 x 1.1/2 UNC-20	5	20	---	ALL	---
9	INOX DIN982 1/4	SS - SELF-LOCKING NUT 1/4	5	22	---	ALL	---

CHAPTER 4 - LEFT LEVER BAR

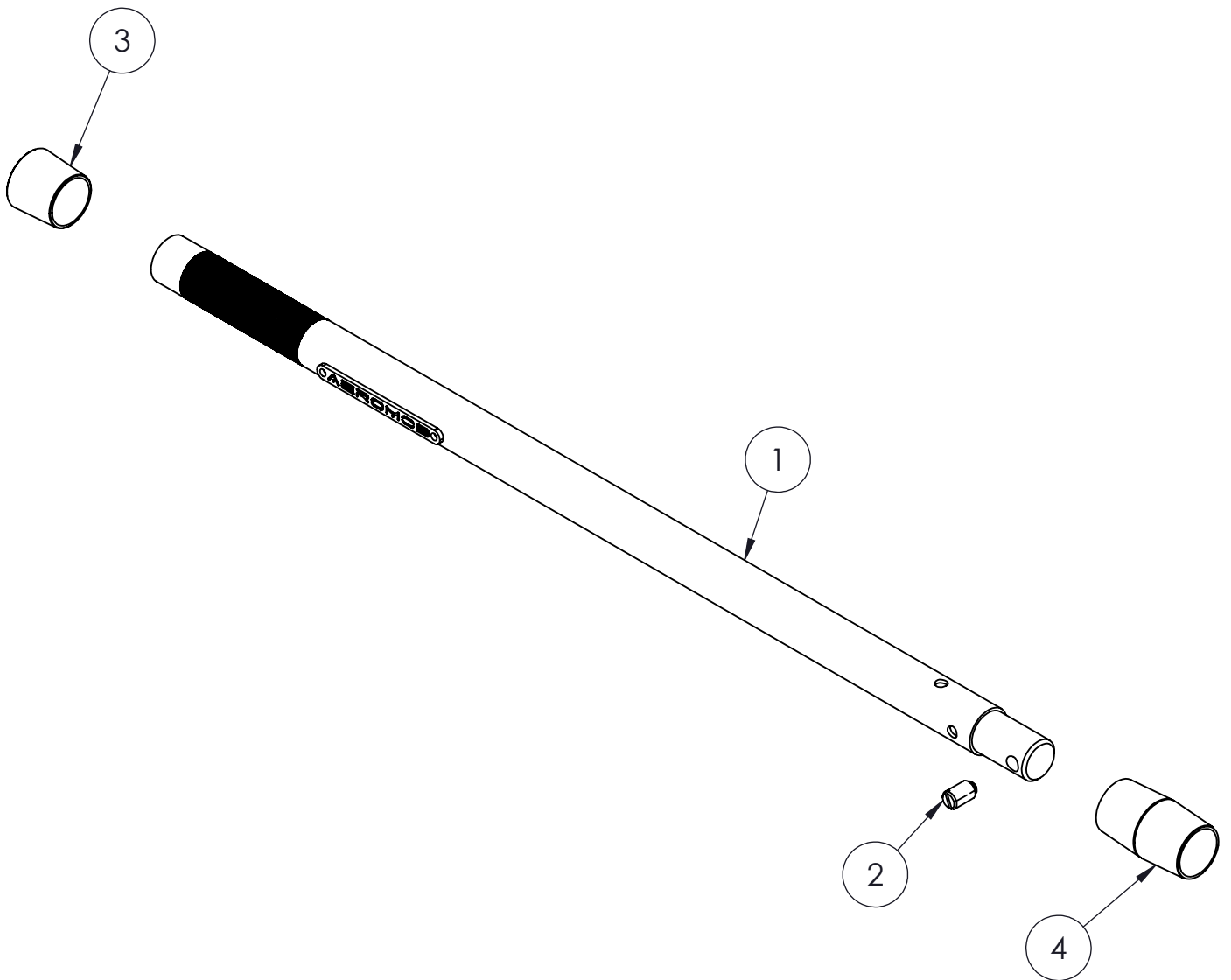
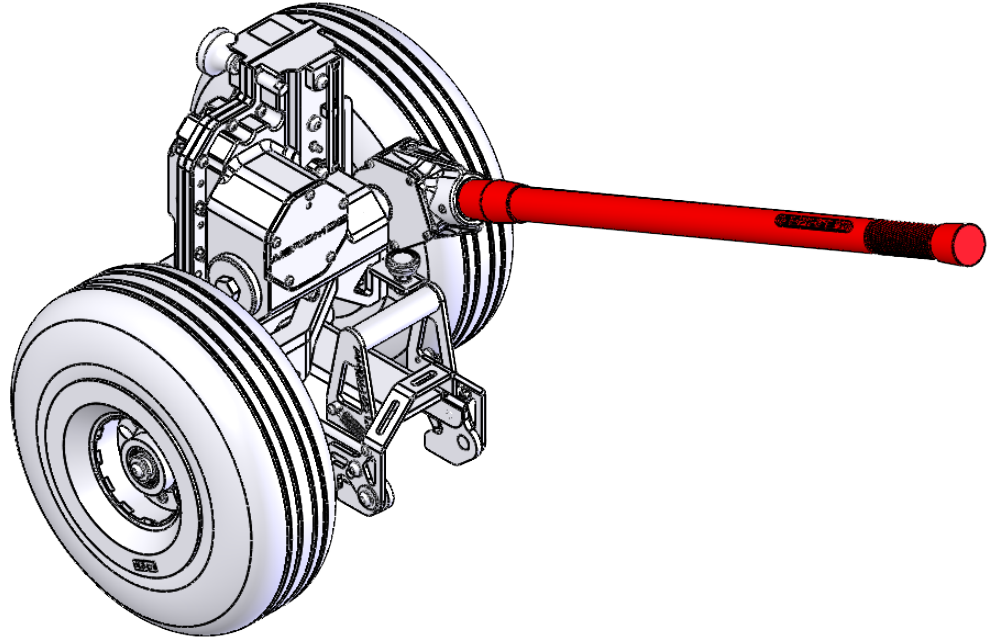

POS	ACTIVE PN	DESCRIPTION	QTY IN THIS DRAWING	QTY EQUIPMENT	OLD PN	APPLICABLE TO SN	AVAIL
1	AM-HDM-145D-S04	WELDED RIGHT LEVER BAR	1	1	---	ALL	---
2	INDEX GN615M12KN	SS - SPRING PLUNGER GN615-M12-KN	1	2	---	ALL	---
3	TAMP3175	END COVER CAP 31,75mm	1	2	---	ALL	---
4	TAMP3175U	MACHINED END COVER CAP 31,75mm	2	4	---	ALL	---

CHAPTER 4 - RIGHT LEVER BAR

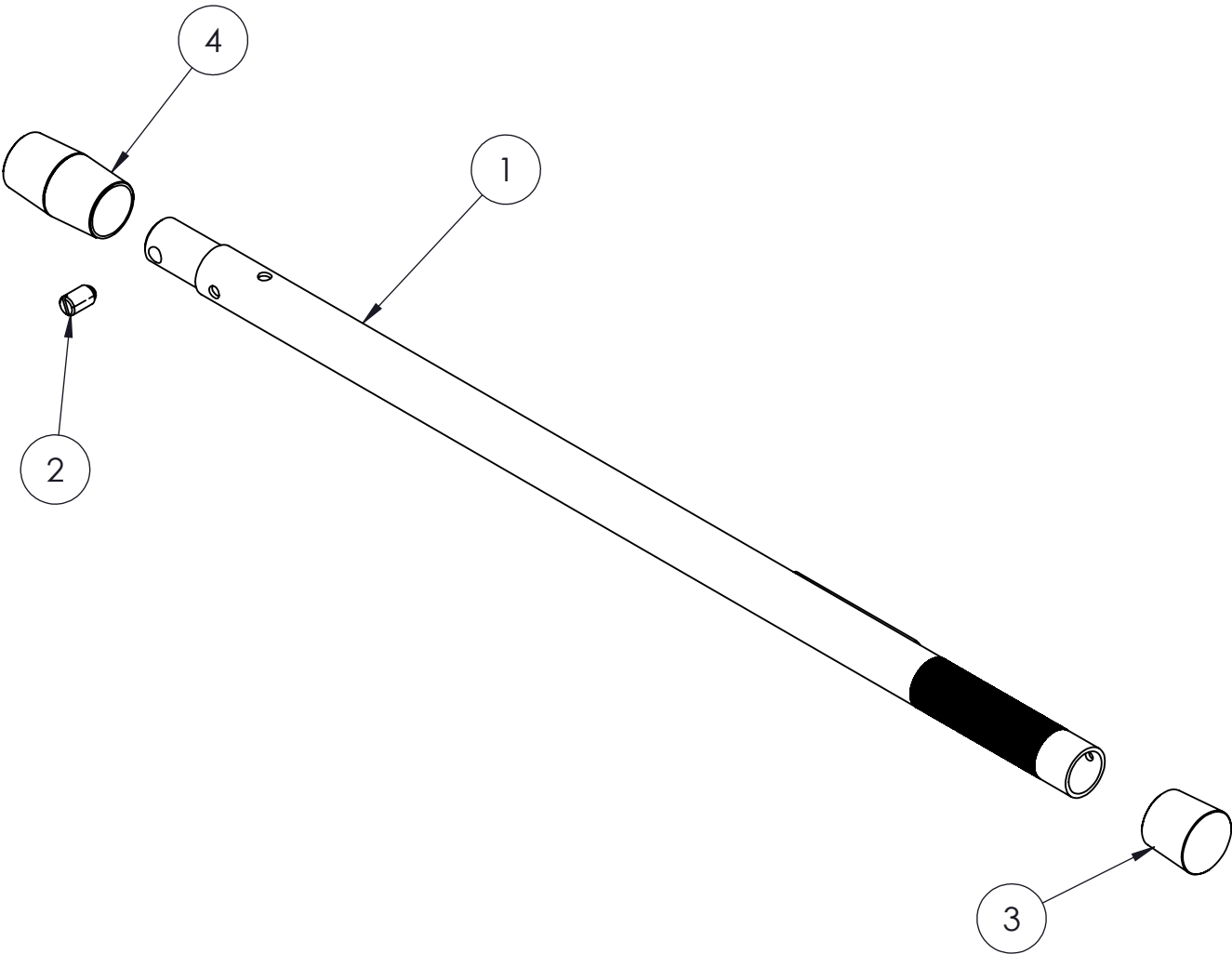
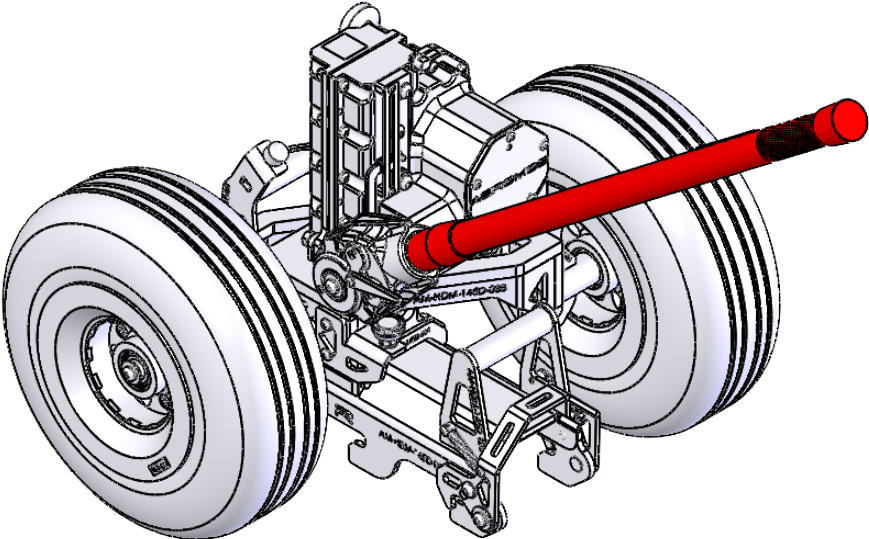

POS	ACTIVE PN	DESCRIPTION	QTY IN THIS DRAWING	QTY EQUIPMENT	OLD PN	APPLICABLE TO SN	AVAIL
1	AM-HDM-145D-S06	WELDED RIGHT LEVER BAR	1	1	---	ALL	---
2	INDEX GN615M12KN	SS - SPRING PLUNGER GN615-M12-KN	1	2	---	ALL	---
3	TAMP3175	END COVER CAP 31,75mm	1	2	---	ALL	---
4	TAMP3175U	MACHINED END COVER CAP 31,75mm	2	4	---	ALL	---

CHAPTER 5 - LEFT RATCHET HANDLE

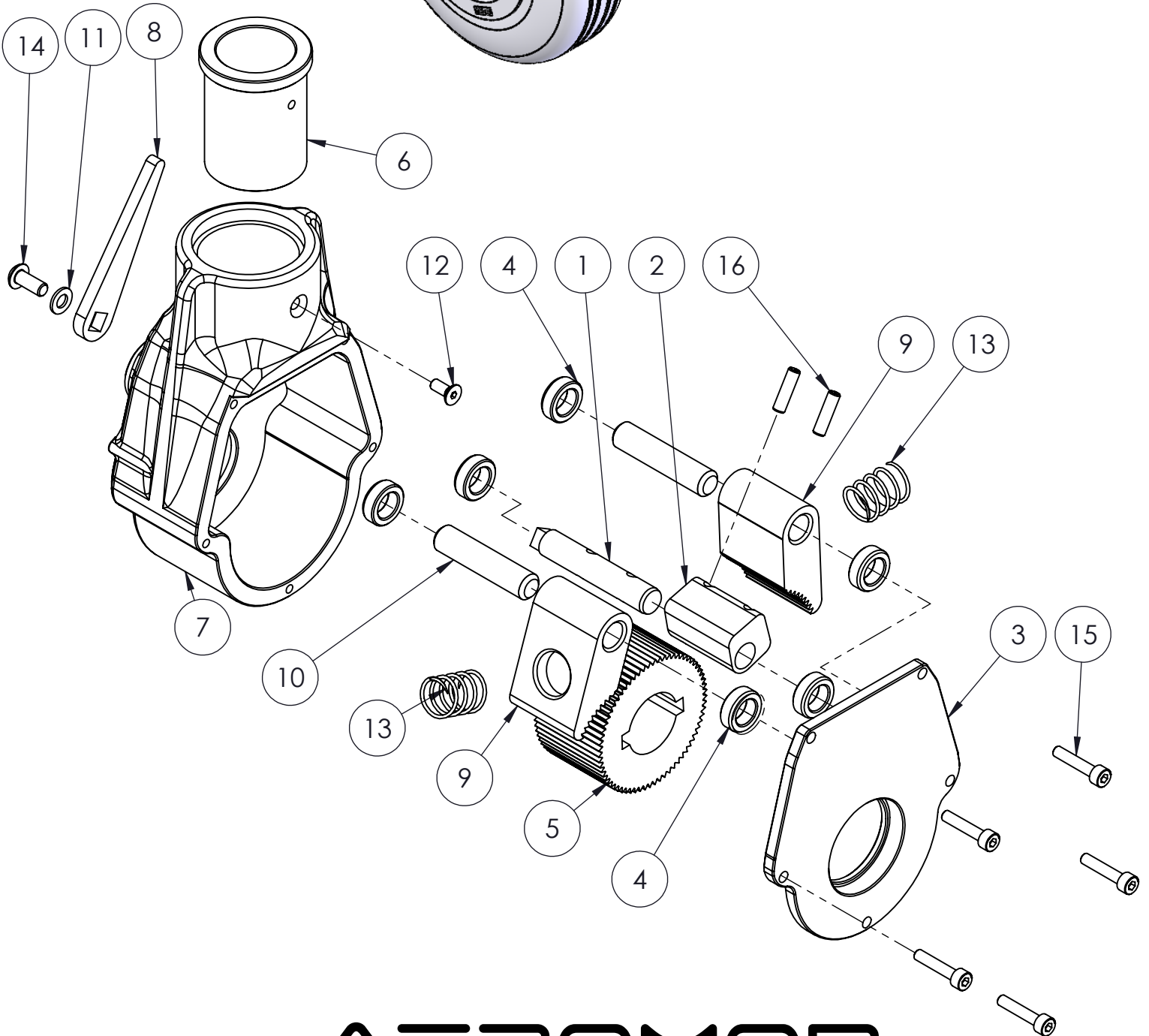
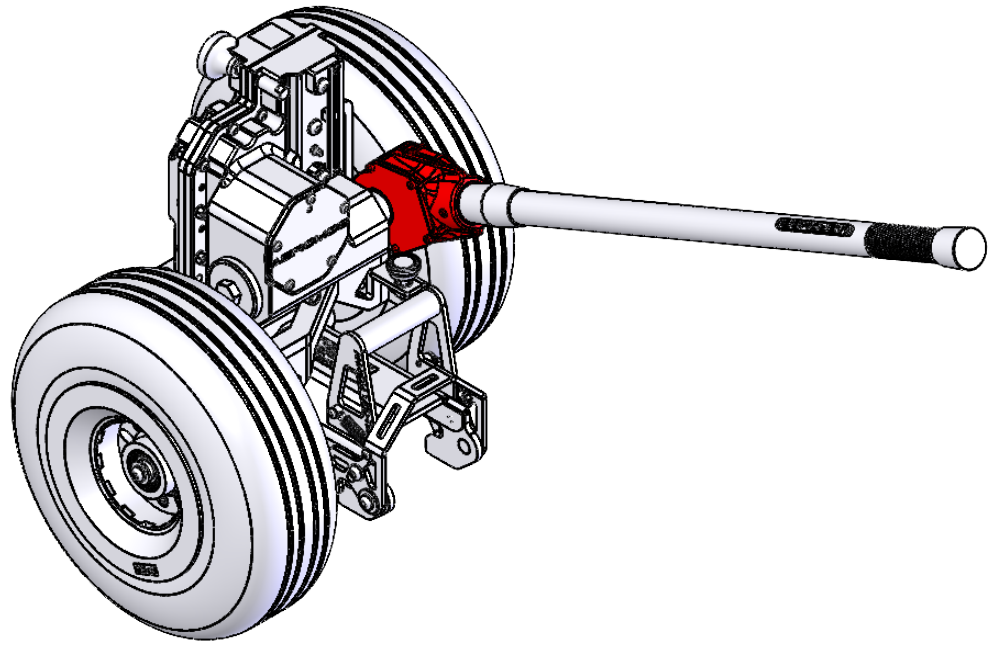

POS	ACTIVE PN	DESCRIPTION	QTY IN THIS DRAWING	QTY EQUIPMENT	OLD PN	APPLICABLE TO SN	AVAIL
1	AM-HDM-145D-045	SELECTOR PIN	1	2	---	ALL	---
2	AM-HDM-145D-055	INNER SELECTOR	1	2	---	ALL	---
3	AM-HDM-145D-020	RATCHER HANDLE COVER	1	2	---	ALL	---
4	AM-HDM-145D-095	BUSHING Ø 10mm	6	12	---	ALL	---
5	AM-HDM-145D-012	RATCHET HANDLE GEAR	1	2	---	ALL	---
6	AM-HDM-145D-016	RATCHER HANDLE BUSHING	1	2	---	ALL	---
7	AM-HDM-145D-011	LEFT RATCHER HANDLE 2.0	1	1	---	ALL	---
8	AM-HDM-145D-019	RATCHET HANDLE LEVER BAR	1	2	---	ALL	---
9	AM-HDM-145D-056	PAWL	2	2	---	ALL	---
10	AM-HDM-145D-069	PAWL SHAFT	2	4	---	ALL	---
11	INOX DIN 125 M5	SS - FLAT WASHER M5	1	14	---	ALL	---
12	INOX DIN7991 M4X10	SS - HS COUNTERSUNK HC SCREW M4X10	1	6	---	ALL	---
13	AM-HDM-145D-112	SS - COMPRESSION SPRING ØE=15,4 X ØI=13 X Ø1,2 X 30	2	4	---	ALL	---
14	DIN7380 M5X10	SS - HS BUTTON H SCREW M5 x 10	1	2	---	ALL	---
15	DIN912 M4X20	SS - HS H CAP SCREW M4X20	5	10	---	ALL	---
16	DIN1481 4X16	SPRING PIN Ø14 x 16	2	4	---	ALL	---

CHAPTER 5 - RIGHT RATCHET HANDLE

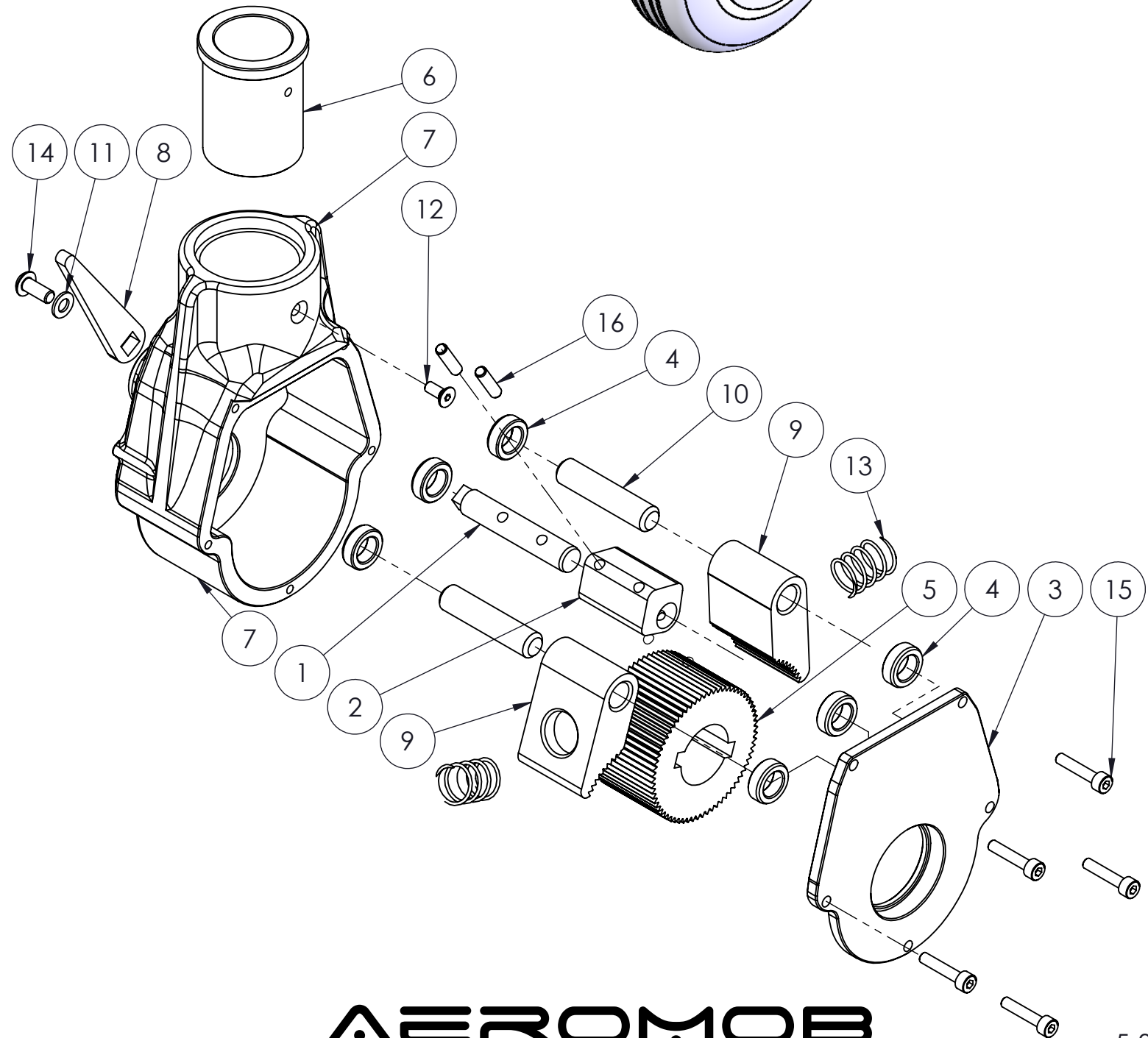
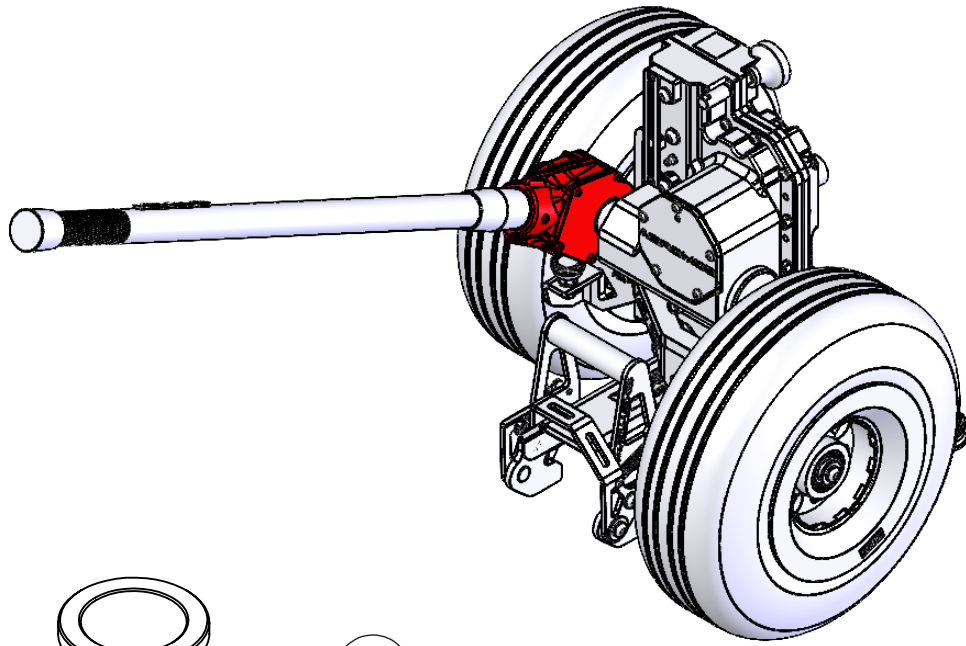

POS	ACTIVE PN	DESCRIPTION	QTY IN THIS DRAWING	QTY EQUIPMENT	OLD PN	APPLICABLE TO SN	AVAIL
1	AM-HDM-145D-045	SELECTOR PIN	1	2	---	ALL	---
2	AM-HDM-145D-055	INNER SELECTOR	1	2	---	ALL	---
3	AM-HDM-145D-020	RATCHER HANDLE COVER	1	2	---	ALL	---
4	AM-HDM-145D-095	BUSHING Ø 10mm	6	12	---	ALL	---
5	AM-HDM-145D-012	RATCHET HANDLE GEAR	1	2	---	ALL	---
6	AM-HDM-145D-016	RATCHER HANDLE BUSHING	1	2	---	ALL	---
7	AM-HDM-145D-057	RIGHT RATCHER HANDLE 2.0	1	1	---	ALL	---
8	AM-HDM-145D-019	RATCHET HANDLE LEVER BAR	1	2	---	ALL	---
9	AM-HDM-145D-056	PAWL	2	2	---	ALL	---
10	AM-HDM-145D-069	PAWL SHAFT	2	4	---	ALL	---
11	INOX DIN 125 M5	SS - FLAT WASHER M5	1	14	---	ALL	---
12	INOX DIN7991 M4X10	SS - HS COUNTERSUNK HC SCREW M4 x 10	1	6	---	ALL	---
13	AM-HDM-145D-112	SS - COMPRESSION SPRING ØE=15,4 X ØI=13 X Ø1,2 X 30	2	4	---	ALL	---
14	DIN7380 M5X10	SS - HS BUTTON H SCREW M5 x 10	1	2	---	ALL	---
15	DIN912 M4X20	SS - HS H CAP SCREW M4 x 20	5	10	---	ALL	---
16	DIN1481 4X16	SPRING PIN Ø14 x 16	2	4	---	ALL	---

CHAPTER 6 - LEFT GRAB

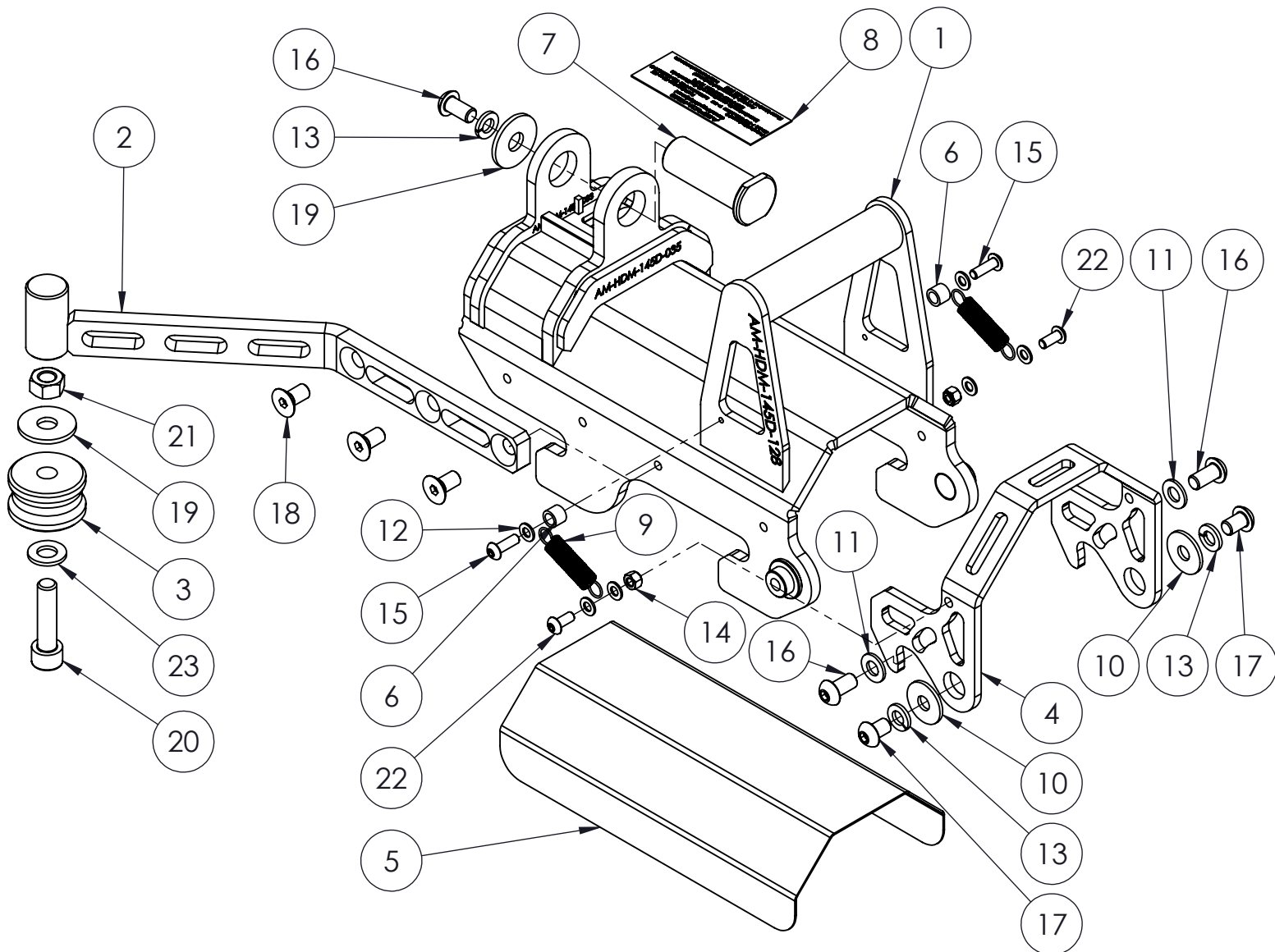
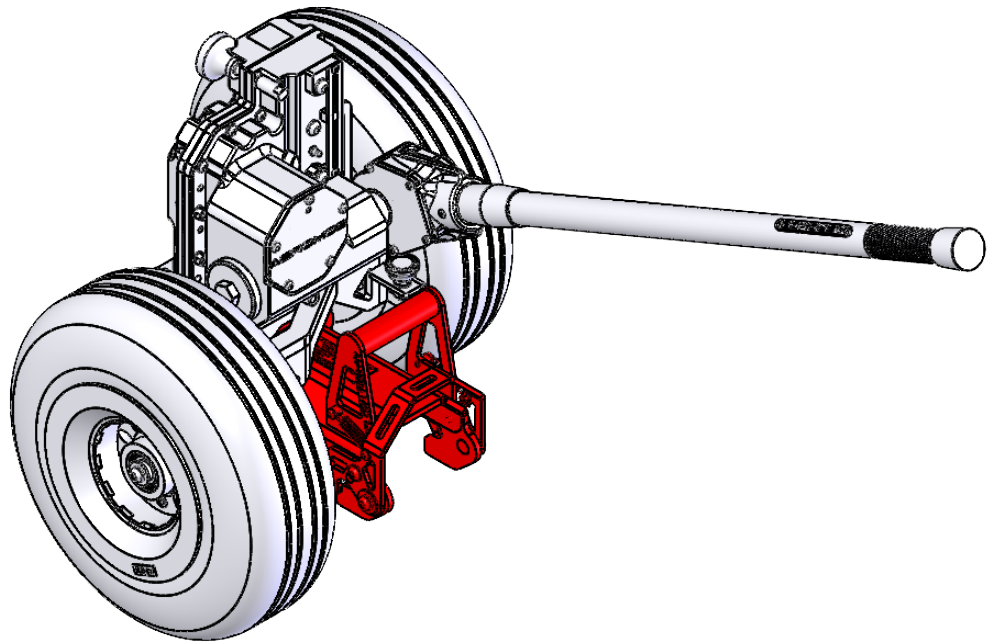

AEROMOB

POS	ACTIVE PN	DESCRIPTION	QTY IN THIS DRAWING	QTY EQUIPMENT	OLD PN	APPLICABLE TO SN	AVAIL
1	AM-HDM-145D-S03	WELDED LEFT GRAB	1	1	---	ALL	---
2	AM-HDM-145D-S07	LEFT GUTTER BRACKET	1	1	---	ALL	---
3	AM-HDM-145D-071	GRAB SUPPORT	1	1	---	ALL	---
4	AM-HDM-145D-041	GRAB LOCK	1	2	---	ALL	---
5	AM-HDM-145D-046	ANTI-ABRASIVE PROTECTION 145	1	2	---	ALL	---
6	AM-HDM-145D-098	GRAB SPACER	2	4	---	ALL	---
7	AM-HDM-145D-042	LOCK PIN	1	2	---	ALL	---
8	AM-HDM-145D-108	ID PLATE 145D	1	2	---	ALL	---
9	MT 1X10X42	TENSION SPRING Ø1 x 10 x 42	2	4	---	ALL	---
10	INOX DIN9021 M8	SS - LARGE FLAT WASHER M8	2	10	---	ALL	---
11	INOX DIN125 M8	SS - FLAT WASHER M8	2	24	---	ALL	---
12	INOX DIN 125 M5	SS - FLAT WASHER M5	6	14	---	ALL	---
13	INOX DIN127 M8	SS - SPLIT LOCK WASHER M8	3	34	---	ALL	---
14	DIN982 M5	SS - SELF-LOCKING NUT M5	2	4	---	ALL	---
15	INOX DIN7380 M5X16	SS - HS BUTTON H SCREW M5 x 16	2	14	---	ALL	---
16	DIN7380 M8X16	SS - HS BUTTON H SCREW M8 x 16	3	6	---	ALL	---
17	DIN7380 M8 X12	SS - HS BUTTON H SCREW M8 x 12	2	4	---	ALL	---
18	DIN7991 M8X16	SS - HS COUNTERSUNK HC SCREW M8 x 16	3	7	---	ALL	---
19	INOX DIN 9021 M10	SS - LARGE FLAT WASHER M10	2	4	---	ALL	---
20	INOX DIN912 M10X40	SS - HS H CAP SCREW M10 x 35	1	2	---	ALL	---
21	INOX DIN934 M10	SS - HEX NUT M10	1	12	---	ALL	---
22	INOX DIN7380 M5X12	SS - HS BUTTON H SCREW M5 x 12	2	4	---	ALL	---
23	INOX DIN125 M10	SS - FLAT WASHER M10	1	2	---	ALL	---

CHAPTER 6 - RIGHT GRAB

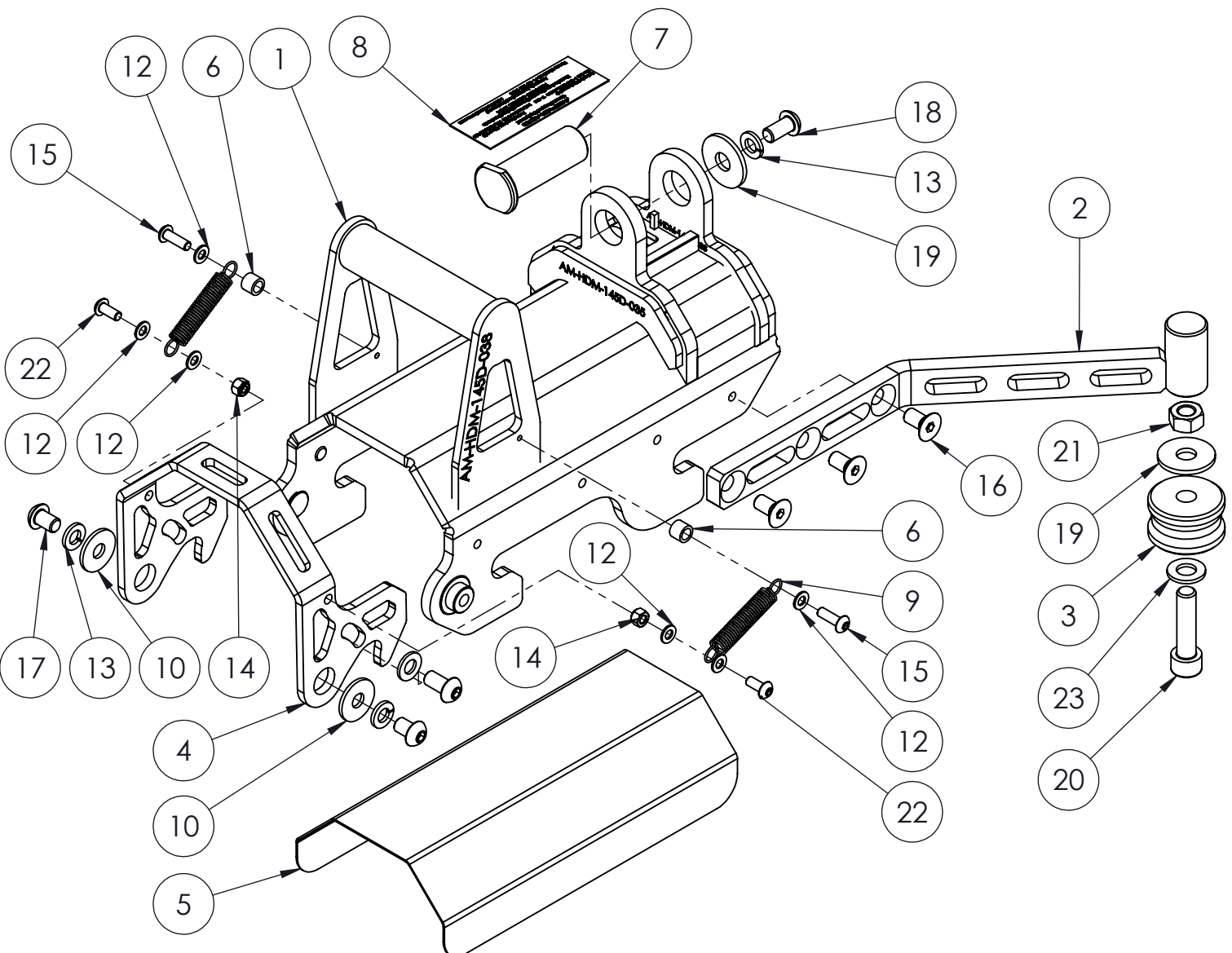
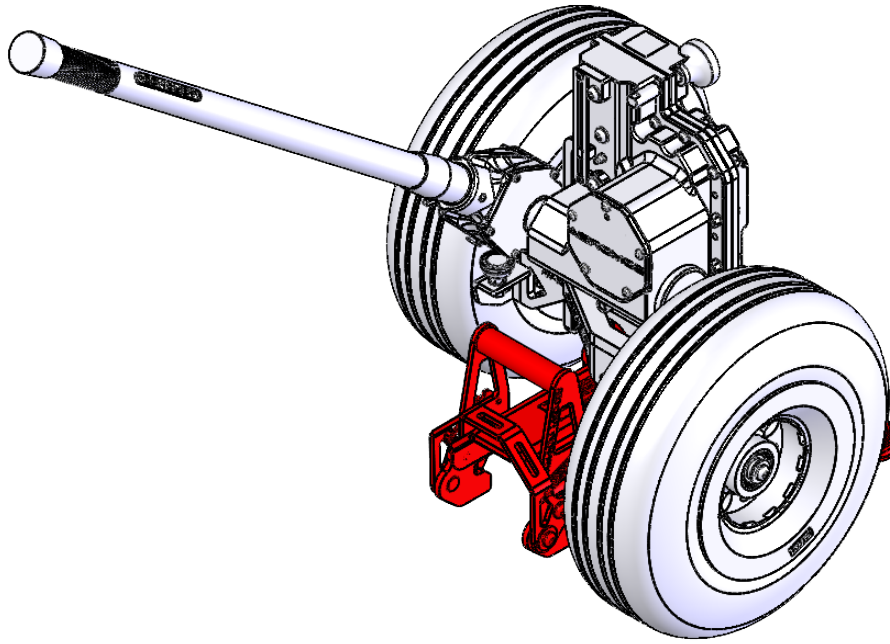

POS	ACTIVE PN	DESCRIPTION	QTY IN THIS DRAWING	QTY EQUIPMENT	OLD PN	APPLICABLE TO SN	AVAIL
1	AM-HDM-145D-S09	WELDED RIGHT GRAB	1	1	---	ALL	---
2	AM-HDM-145D-S08	RIGHT GUTTER BRACKET	1	1	---	ALL	---
3	AM-HDM-145D-071	GRAB SUPPORT	1	1	---	ALL	---
4	AM-HDM-145D-041	GRAB LOCK	1	2	---	ALL	---
5	AM-HDM-145D-046	ANTI-ABRASIVE PROTECTION 145	1	2	---	ALL	---
6	AM-HDM-145D-098	GRAB SPACER	2	4	---	ALL	---
7	AM-HDM-145D-042	LOCK PIN	1	2	---	ALL	---
8	AM-HDM-145D-108	ID PLATE 145D	1	2	---	ALL	---
9	MT 1X10X42	MOLA DE TRACÃO Ø1 x Ø10 x 42	2	4	---	ALL	---
10	INOX DIN9021 M8	SS - LARGE FLAT WASHER M8	2	10	---	ALL	---
11	INOX DIN125 M8	SS - FLAT WASHER M8	2	24	---	ALL	---
12	INOX DIN 125 M5	SS - FLAT WASHER M5	6	14	---	ALL	---
13	INOX DIN127 M8	SS - SPLIT LOCK WASHER M8	3	34	---	ALL	---
14	DIN982 M5	SS - SELF-LOCKING NUT M5	2	4	---	ALL	---
15	INOX DIN7380 M5X16	SS - HS BUTTON H SCREW M5 x 16	2	14	---	ALL	---
16	DIN7991 M8X16	SS - HS COUNTERSUNK HC SCREW M8 x 16	3	6	---	ALL	---
17	DIN7380 M8 X12	SS - HS BUTTON H SCREW M8 x 12	2	4	---	ALL	---
18	DIN7380 M8X16	SS - HS BUTTON H SCREW M8 x 16	3	7	---	ALL	---
19	INOX DIN 9021 M10	SS - LARGE FLAT WASHER M10	2	4	---	ALL	---
20	INOX DIN912 M10X40	SS - HS H CAP SCREW M10 x 35	1	2	---	ALL	---
21	INOX DIN934 M10	SS - HEX NUT M10	1	12	---	ALL	---
22	INOX DIN7380 M5X12	SS - HS BUTTON H SCREW M5 x 12	2	4	---	ALL	---
23	INOX DIN125 M10	SS - FLAT WASHER M10	1	2	---	ALL	---