

To lock the latch, pull it out and turn it.
Vertical position: locked
Horizontal position: loose

DETAIL A
 SCALE 1 : 4

STEP 1: ASSEMBLY OF CASTERS AND LOCKS

- Support the CARTMOB frame on a suitable surface, such as two reinforced trestles, with bottom facing up
- Remove the basket from the set;
- Position the casters on the frame, in their respective positions, as shown;
- Insert the screws from bottom to top, as shown;
- Replace the basket;
- Place the lock on the caster flange as shown in the image (DETAIL_A);
- Tighten the caster screws.

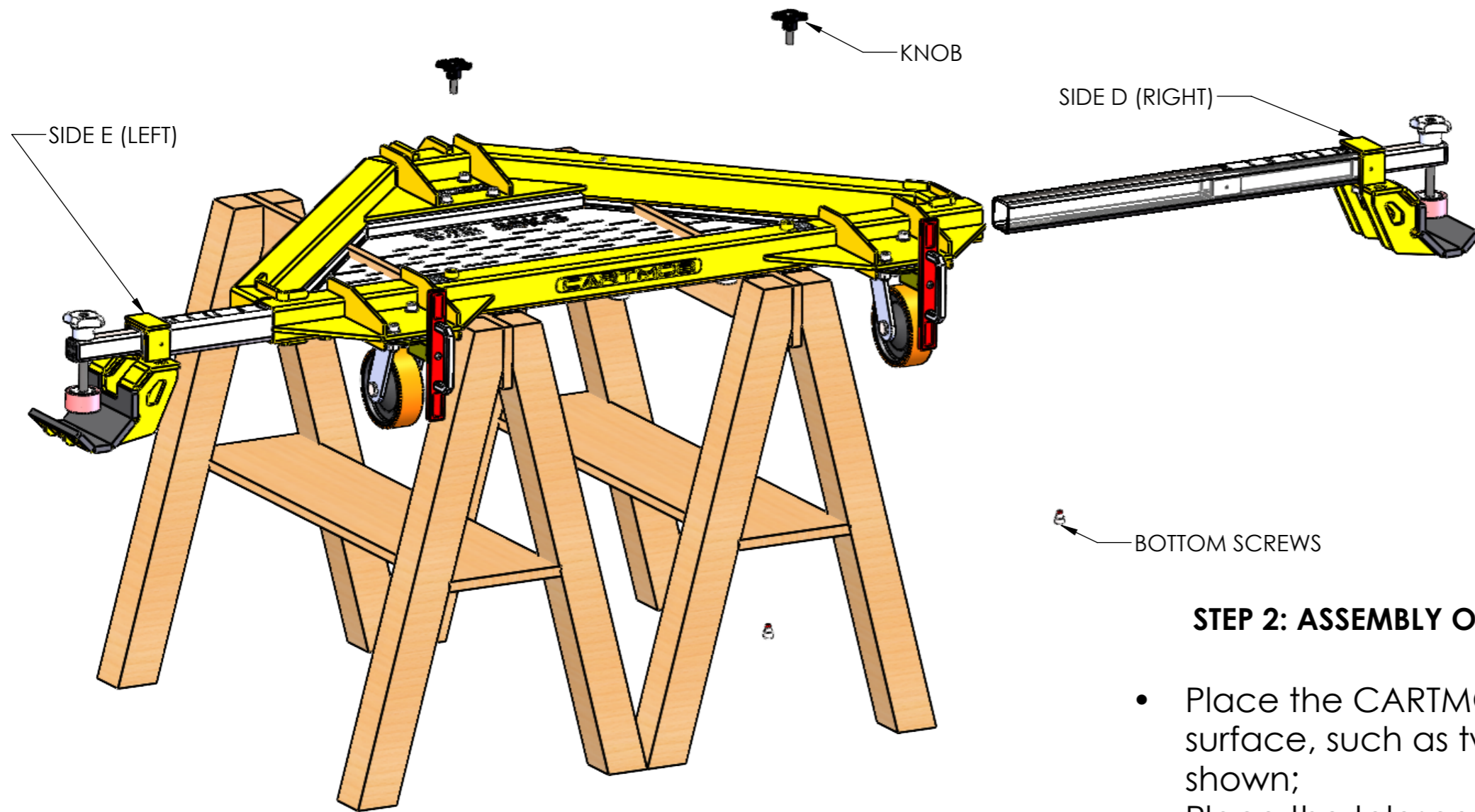

STEP 2: ASSEMBLY OF CLAW ARM

- Place the CARTMOB frame on a suitable surface, such as two reinforced trestles, as shown;
- Place the telescopic arms on their respective sides, D and E, as shown;
- Lock the telescopic arms with the 2 handles from above and the 2 screws from below, as shown;

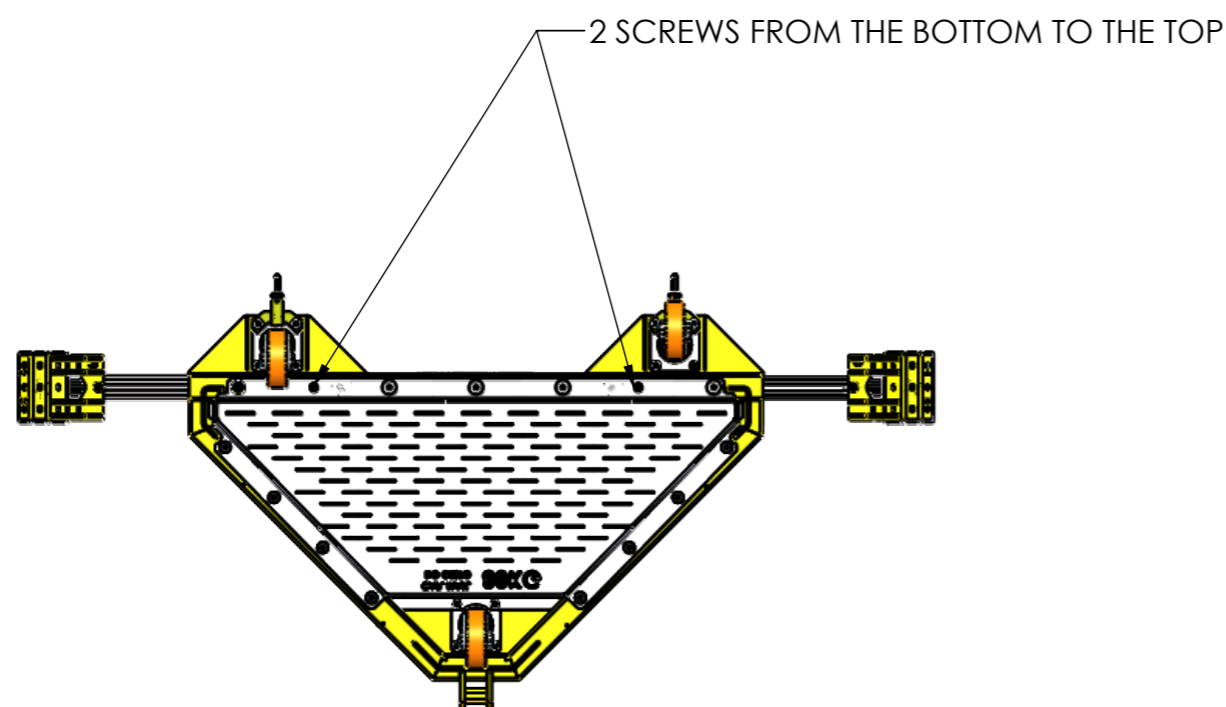

STEP 3: ASSEMBLY OF TOWBAR

- Position the equipment on the ground;
- Attach part of the towbar to the equipment. Insert the pin to attach the towbar to the equipment, according to DETAIL G.
IMPORTANT: The towbar must be aligned with the ground. It must not be positioned at an angle. Engage the pin by hand, **without knocking or forcing it into place**. Move the towbar and pin slightly until they are safely attached;
- Apply threadlocker to the pin screw, as indicated in DETAIL G.
- Join the parts of the towbar with the M12 bolts, washers and self-locking nuts (DETAIL F).

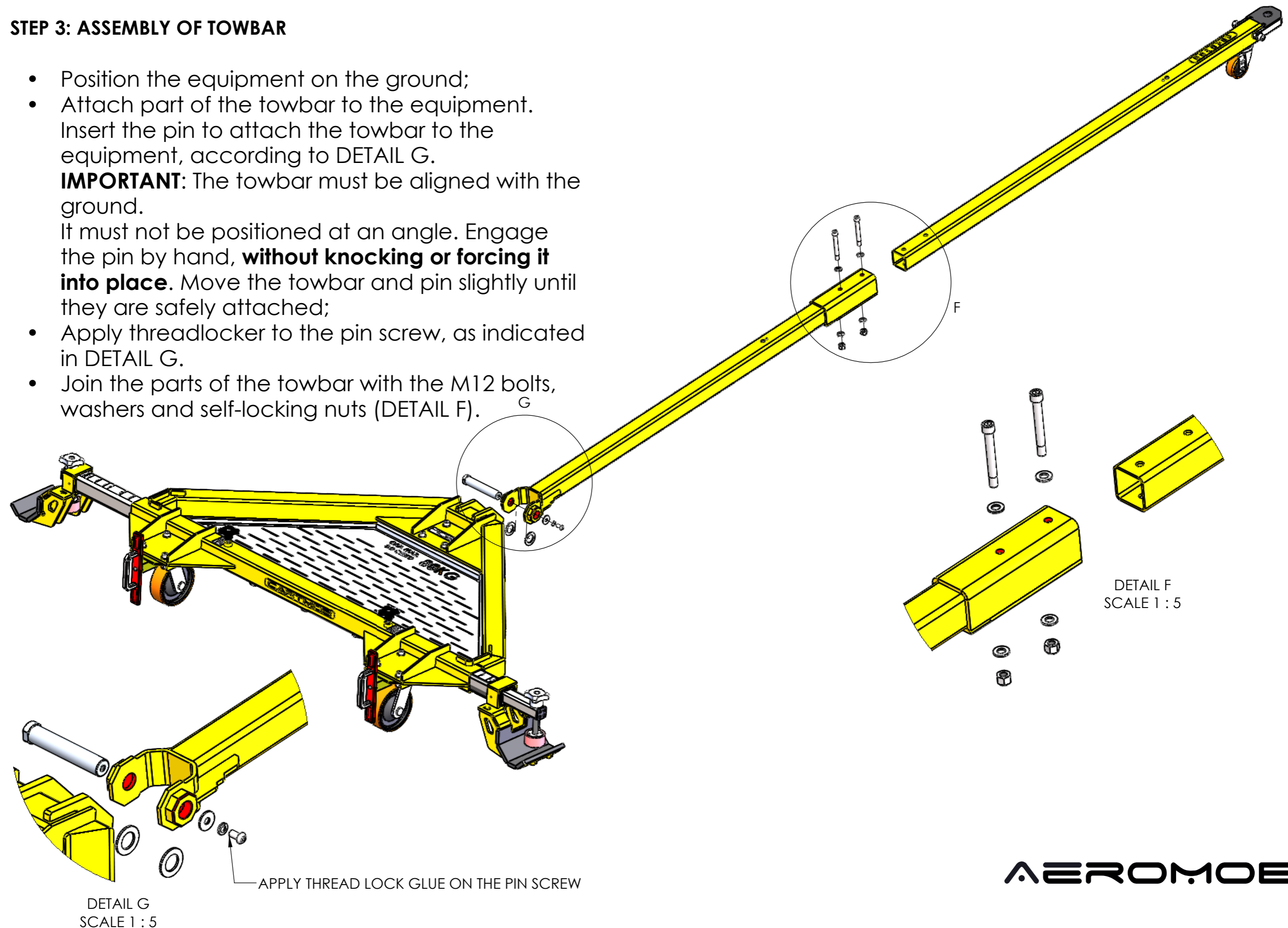

DETAIL G
SCALE 1 : 5

APPLY THREAD LOCK GLUE ON THE PIN SCREW

DETAIL F
SCALE 1 : 5

AEROMOB