

AEROMOB

ILLUSTRATED PARTS CATALOGUE

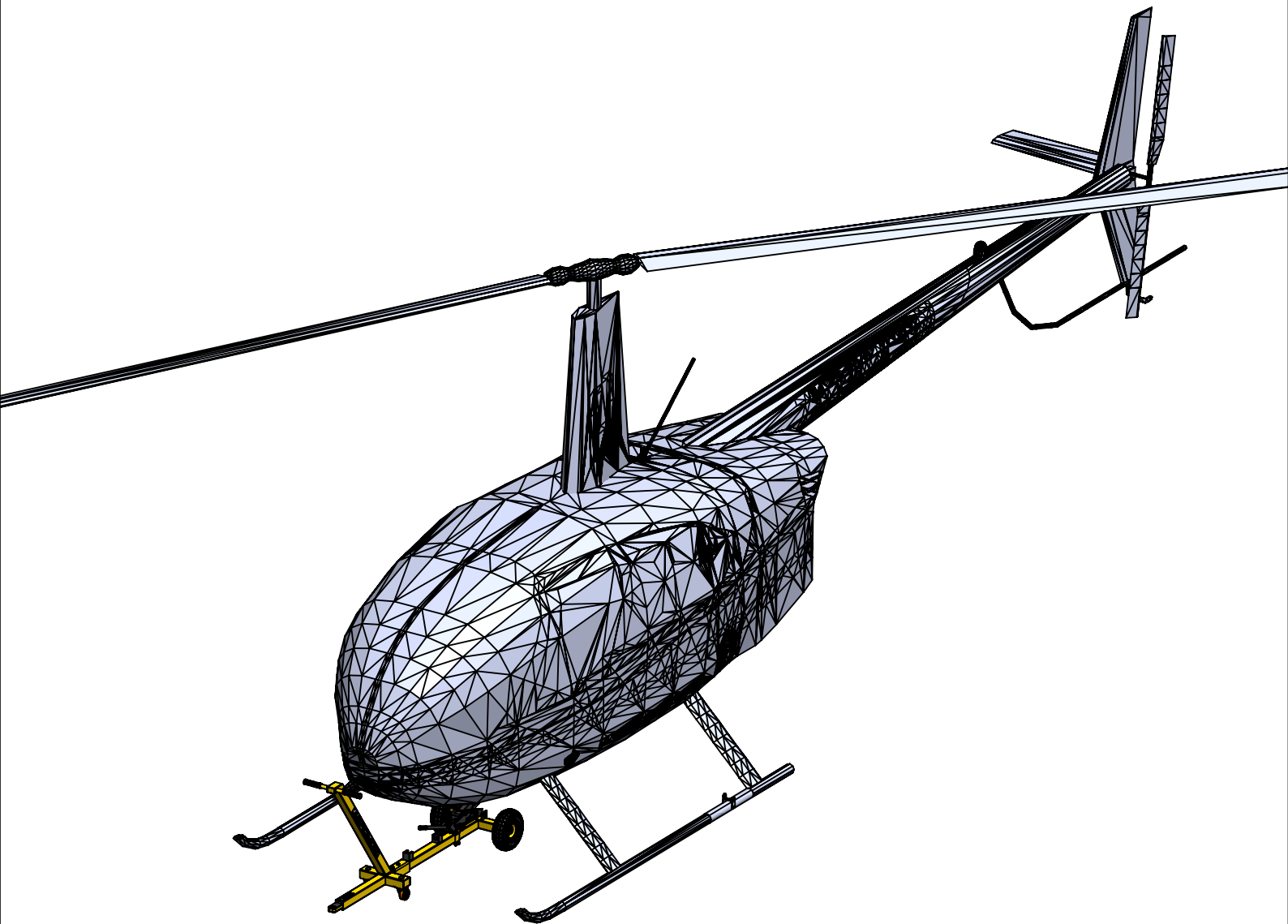

EQUIPMENT NAME: FORKMOB 66
PART NUMBER: AM-FRK-66-K01

AEROMOB

ILLUSTRATED PARTS CATALOGUE

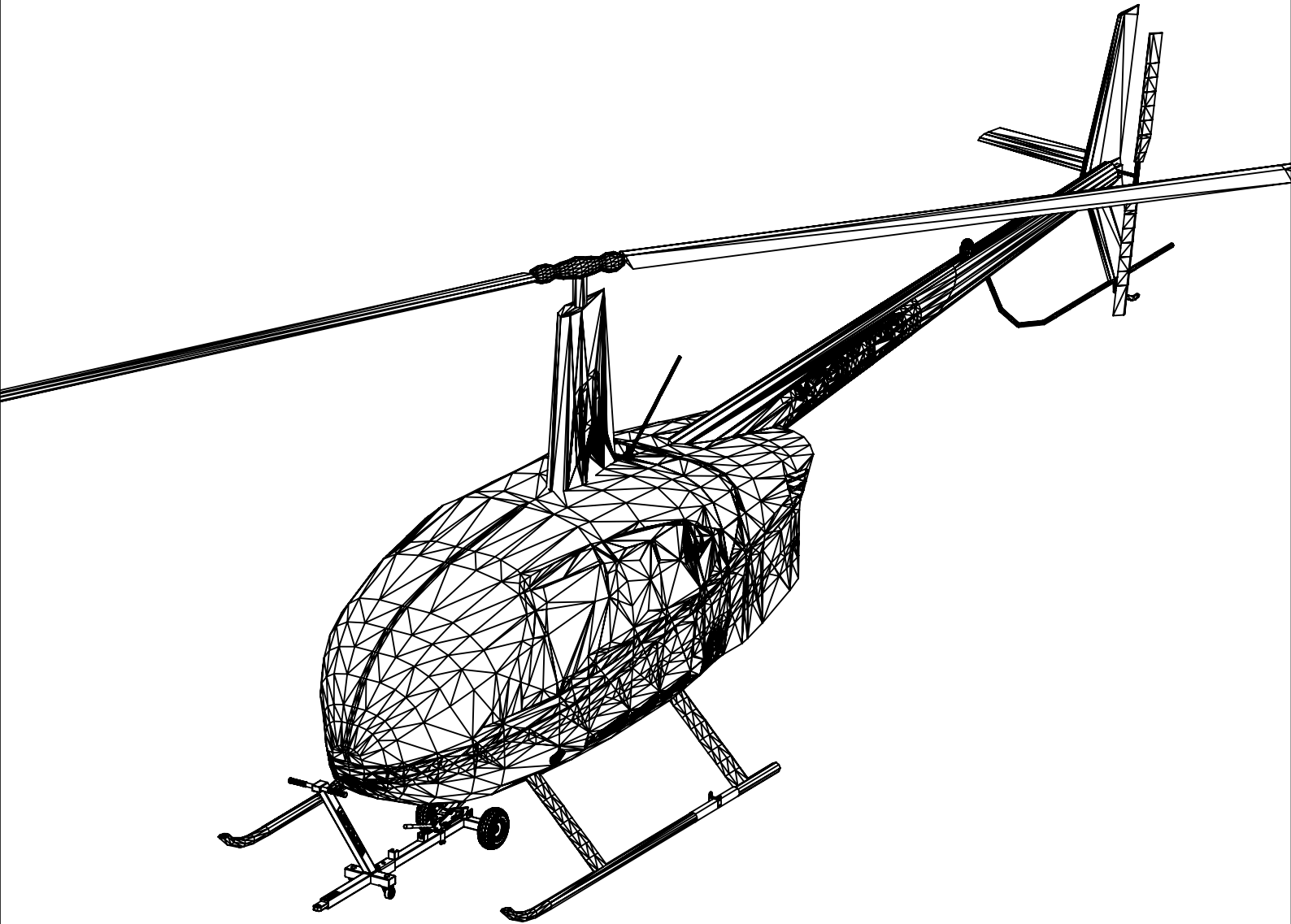

Aeromob Aeronautical Equipment Ltda

CNPJ: 40.061.679/0001-43

Address: Carlos Willy Boehm 990 Street - Costa e Silva

Postcode: 89218-325 / Joinville - SC

Phone: +55 (47) 4101-2724 | 9 9937-9077

Site: www.aeromob-industry.com

Contact Aeromob for more information on
parts and products.

INTRODUCTION

The Illustrated Parts Catalog (IPC) must be used to identify parts and component replacement request. The IPC should never be used as a component removal, installation and maintenance procedure. This catalog is used in conjunction with the Equipment Maintenance Manual (MM). The structure of chapters and details used in this IPC follow the applicable standards as Air Transport Association (ATA) SPEC 100 and iSPEC 2200.

The catalog features:

1. A list of chapters;
2. An isometric view of the equipment with emphasis on the set shown in the chapter;
3. An exploded view of each equipment set and its respective list of components;
4. The numbering of the pages is composed initially by the number of the chapter and followed by chapter page number.

PART DESIGNATION

AEROMOB parts are designated using the following code:

AM-HDM-135-S01

such that,

AM: AEROMOB

HDM: Represents the family of equipment

135: the equipment model

S01: represents the part-specific code.

On standard components purchased from third parties such as screws bearings, etc., the codes are varied, according to the necessary specification in each item. In some cases, manufacturers codes are also used.

AEROMOB special tools are designated with an "FM" prefix keeping then the identification code of the equipment to which it is applied.

AEROMOB

INTRODUCTION

PARTS AVAILABILITY

"YES" indicates the part is available as a separate replacement item.

"NO" indicates that the part is no longer available or is only available as part of a set.

ABBREVIATIONS

BICROM - Bichromated

CL - Class

DISP - Parts availability

SS - Stainless steel

HS - Hexagon socket

WS - Worm shaft

TS - Top Shaft

GUARANTEE

AEROMOB applies the standard 1-year warranty on parts and components purchased from AEROMOB or an authorized dealer.

RETURNS

No unused parts may be returned to AEROMOB for credit if the parts show any indication of wear or damage, or if the cost of the individual part is less than \$25 (US). Parts returned within 30 days of purchase will be valued at a 20% restocking fee. no part may be returned after 30 days without AEROMOB's prior approval. Any parts approved for return after 30 days will be evaluated at a fee 50% restocking fee.

AEROMOB

INTRODUCTION

This document is copyrighted. The total or partial copy of the text, images or tables without the authorization of AEROMOB is expressly prohibited, subjecting the violator to the appropriate civil and criminal penalties.

AEROMOB

REVISION

Revision Number	Date

To access the updated version of this document, point your device at the QR CODE below



www.aeromob.com.br/support-am-frk-66-k01

AEROMOB

SUMMARY

CHAPTER 1 - PRINCIPAL BODY	1-1
BILL OF MATERIALS	1-2
CHAPTER 2 - SECOND BODY	2-1
BILL OF MATERIALS	2-2
CHAPTER 3 - WHEELS	3-1
BILL OF MATERIALS	3-2
CHAPTER 4 - ELEVATION SYSTEM	4-1
BILL OF MATERIALS	4-2
CHAPTER 5 - LOCK BOX	5-1
BILL OF MATERIALS	5-2

CHAPTER 1 - PRINCIPAL BODY

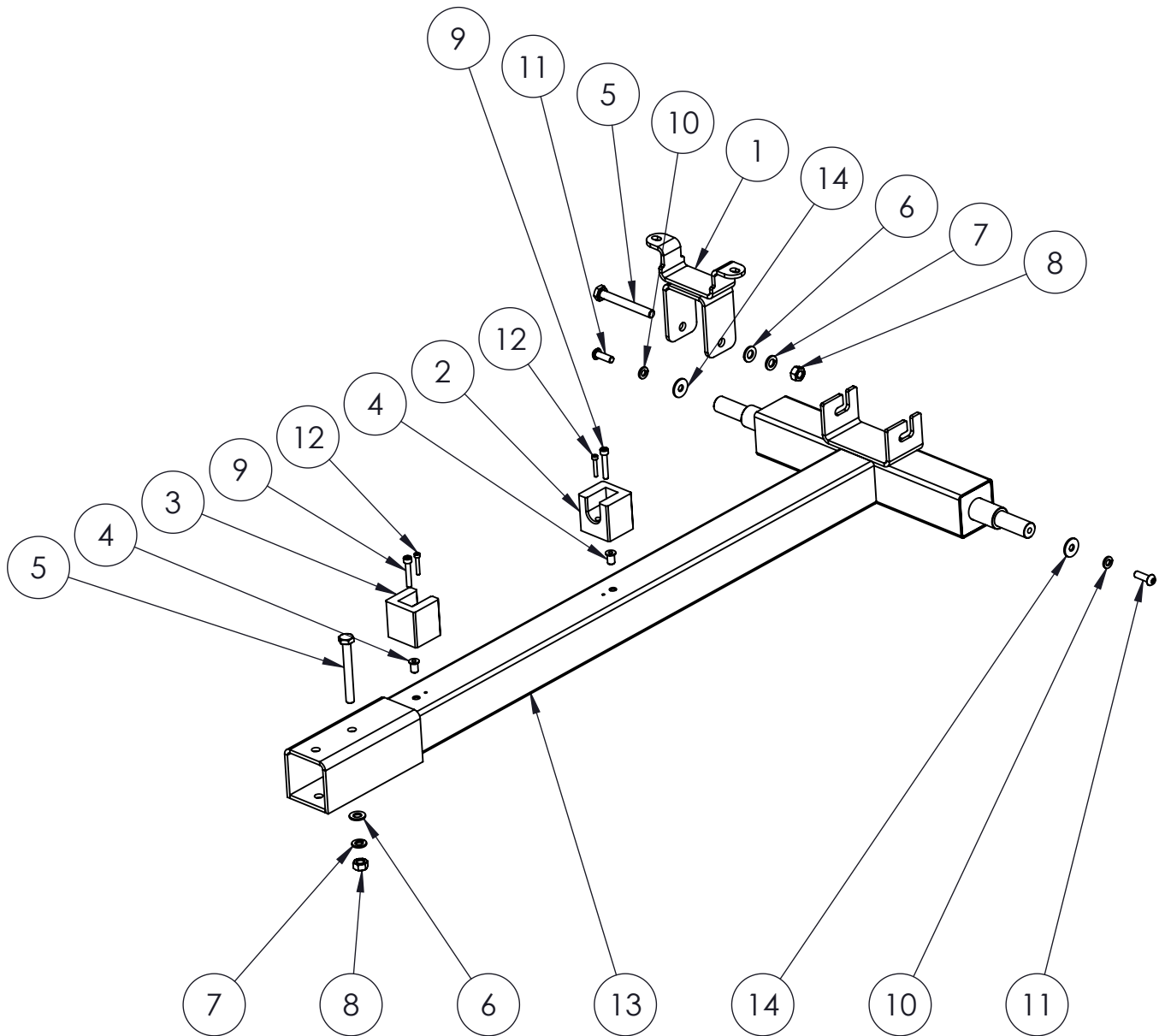
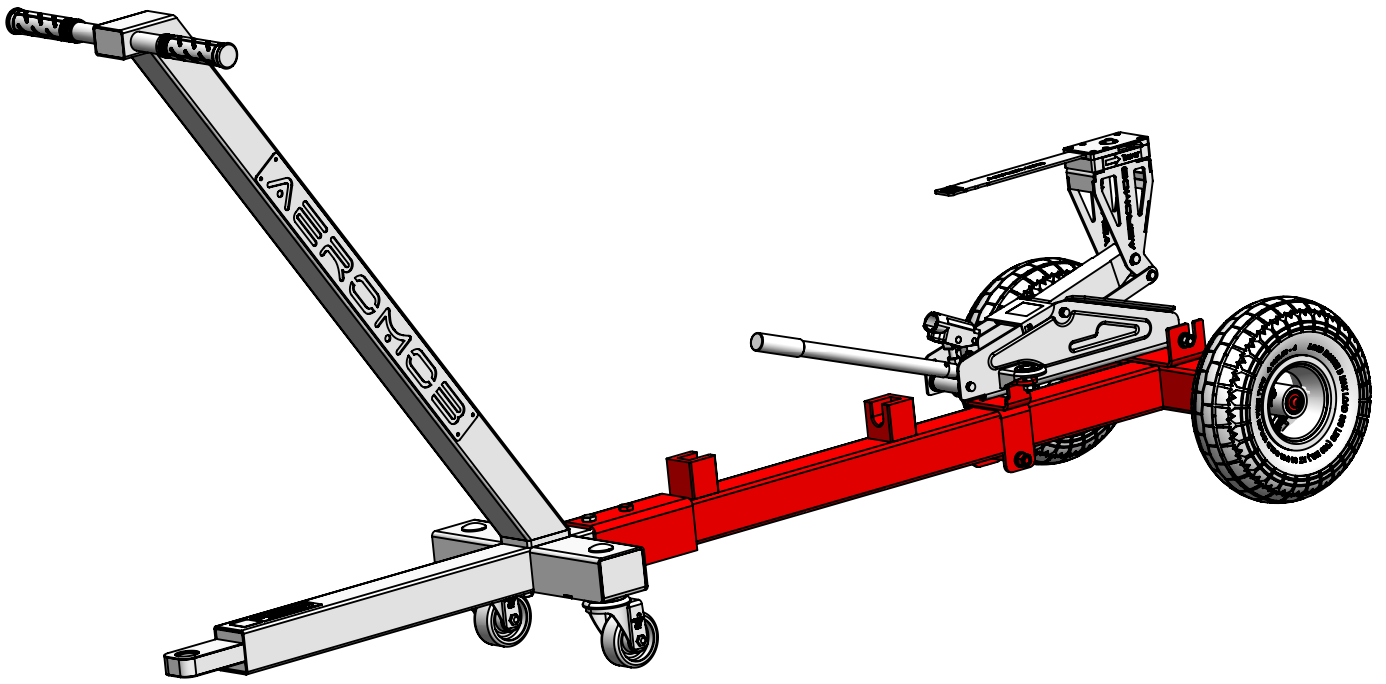

AEROMOB

POS.	ACTIVE PN	DESCRIPTION	QTY IN THIS DRAWING	QTY EQUIPMENT	OLD PN	APPLICABLE TO SN	AVAIL
1	AM-FRK-S03	SUPPORT	1	1	FORK.S_03	ALL	---
2	AM-FRK-018	LEVER SUPPORT	1	1	FORK_18	ALL	---
3	AM-FRK-019	LEVER SUPPORT	1	1	FORK_19	ALL	---
4	REBR M6X15	THREADED RIVET M6X15	2	2	----	ALL	---
5	DIN933 M10X85	HEX SCREW M10 x 85	2	3	----	ALL	---
6	INOX DIN125 M10	WASHER M10	2	5	---	ALL	---
7	DIN 127-M18	LOCK WASHER M10	2	5	---	ALL	---
8	DIN 934 M10	HEX NUT M10	2	3	---	ALL	---
9	DIN912 M6X35 CL	INT HEX CIL HEAD SCREW M6X35	2	2	----	ALL	---
10	INOX DIN127 M8	LOCK WASHER M8	2	2	---	ALL	---
11	DIN7380 M8X25	INT HEX BUTTON SCREW M8 x 25	2	2	----	ALL	---
12	DIN912 M4X25	INT HEX CIL HEAD SCREW M4x25	2	2	----	ALL	---
13	AM-FRK-66-S01	PRINCIPAL BODY	1	1	FORK.S_01	ALL	---
14	INOX DIN9021 M8	LARGE WASHER M8	2	2	---	ALL	---

CHAPTER 2 - SECOND BODY

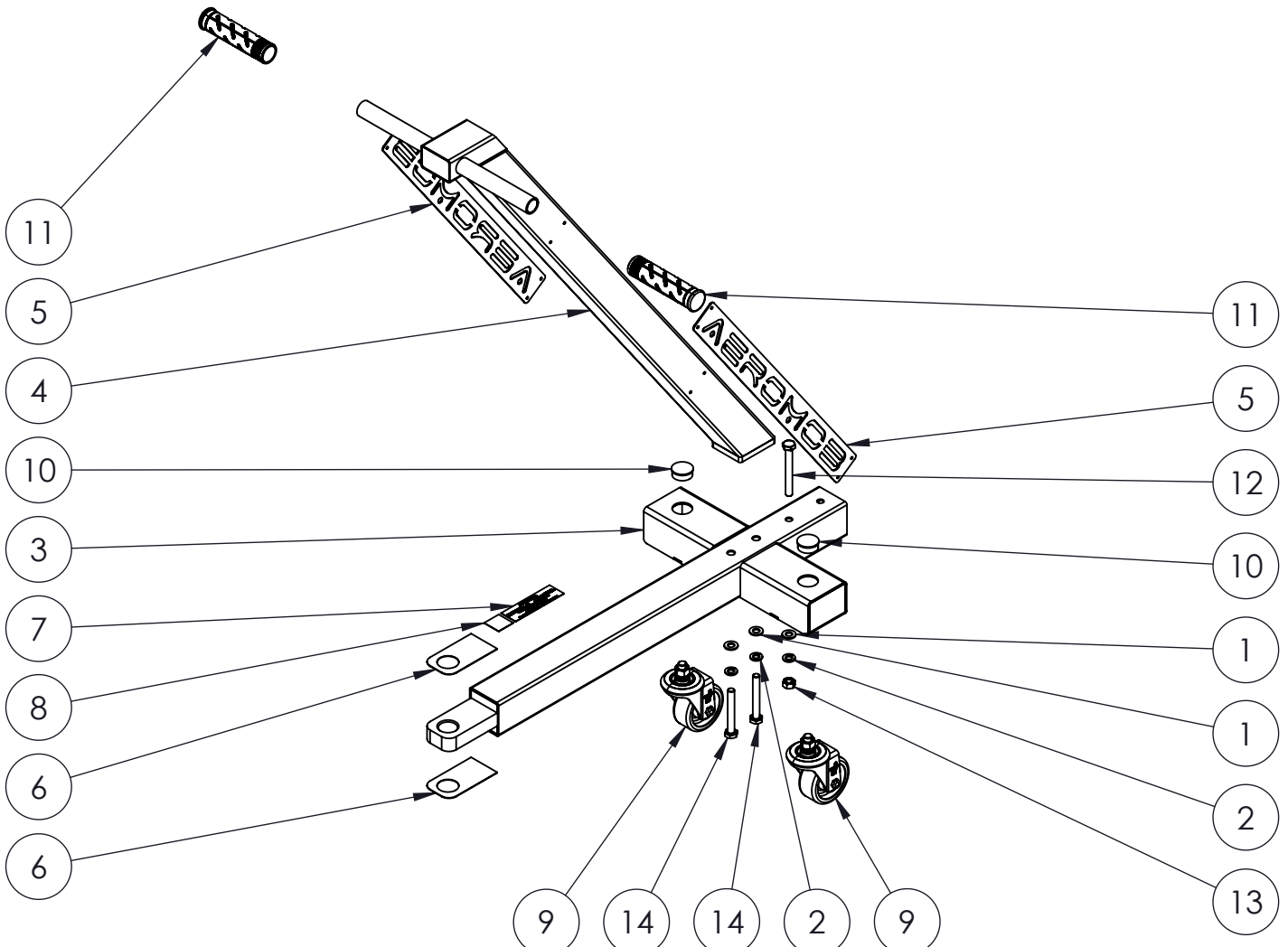
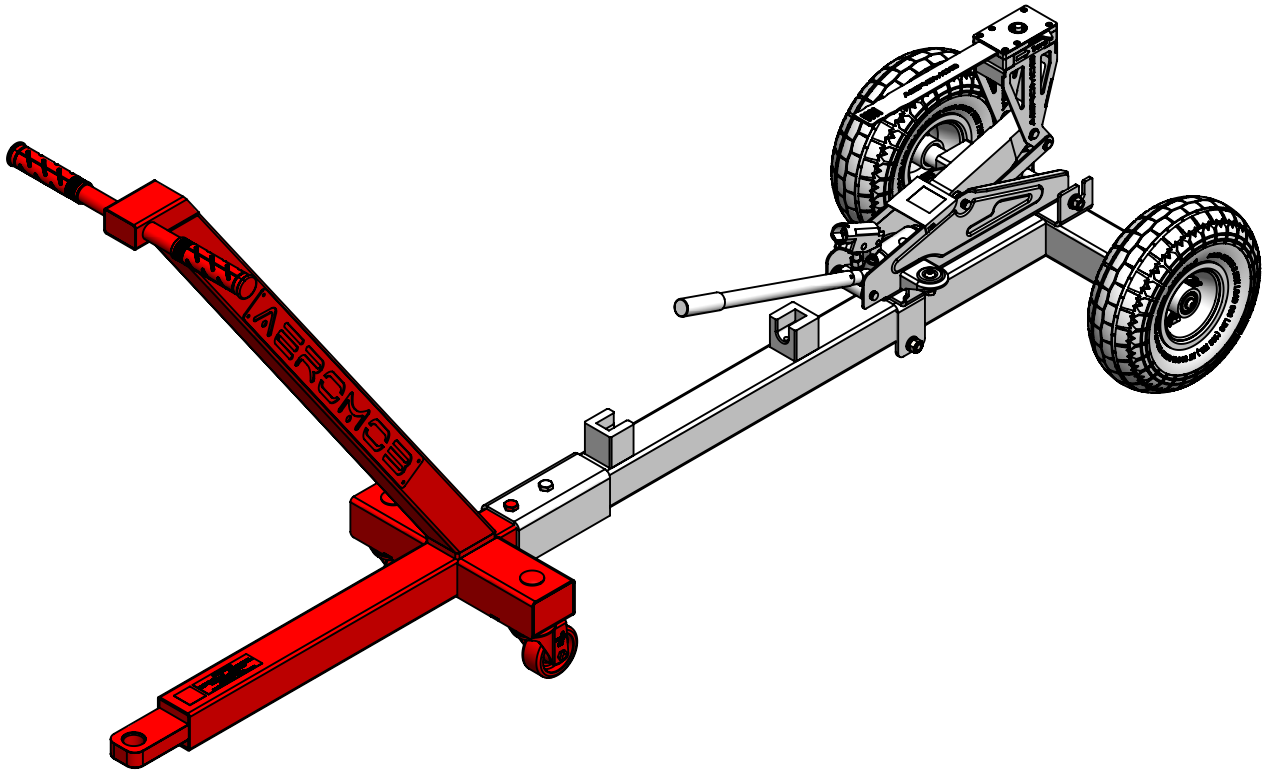

AEROMOB

POS.	ACTIVE PN	DESCRIPTION	QTY IN THIS DRAWING	QTY EQUIPMENT	OLD PN	APPLICABLE TO SN	AVAIL
1	INOX DIN125 M10	WASHER M10	3	2	---	ALL	---
2	DIN 127-M18	LOCK WASHER M10	3	2	---	ALL	---
3	AM-FRK-S02	SECOND BODY	1	1	FORK.S_02	ALL	---
4	AM-FRK-S05	DIRECTION BODY	1	1	FORK.S_05	ALL	---
5	AM-FRK-013	AEROMOB PLATE	2	2	FORK_13	ALL	---
6	AM-FRK-039	CARPET	2	2	FORK_39	ALL	---
7	AM-FRK-051	IDENTIFICATION PLATE	1	1	---	ALL	---
8	AM-FRK-66-054	QR CODE_MANUAL PLATE	1	1	---	ALL	---
9	GLE.312.PE	SCHIOPPA 3" ROTATION	2	2	GLE.312.PE	ALL	---
10	TAMP30	PLUG FOR TUBE 30mm	2	2	TAMP30	ALL	---
11	MANOPLA P1	BLACK GLOVE Ø 25mm	2	2	----	ALL	---
12	DIN933 M10X85	HEX SCREW M10 x 85	1	2	----	ALL	---
13	DIN 934 M10	HEX NUT M10	1	2	---	ALL	---
14	DIN933 M10X75	HEX SCREW M10 x 75	2	2	----	ALL	---

CHAPTER 3 - WHEELS

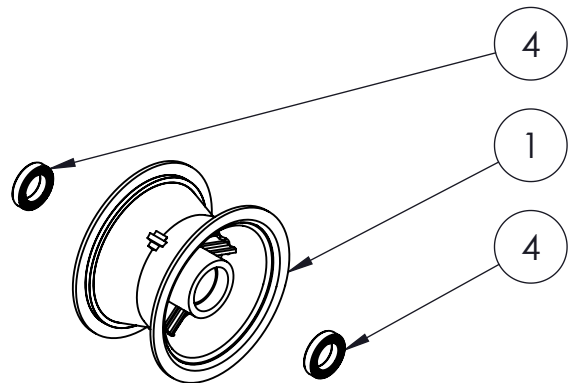
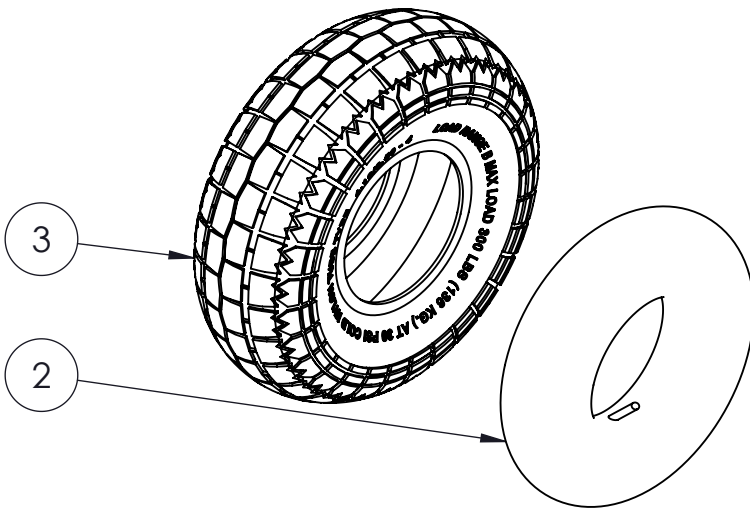
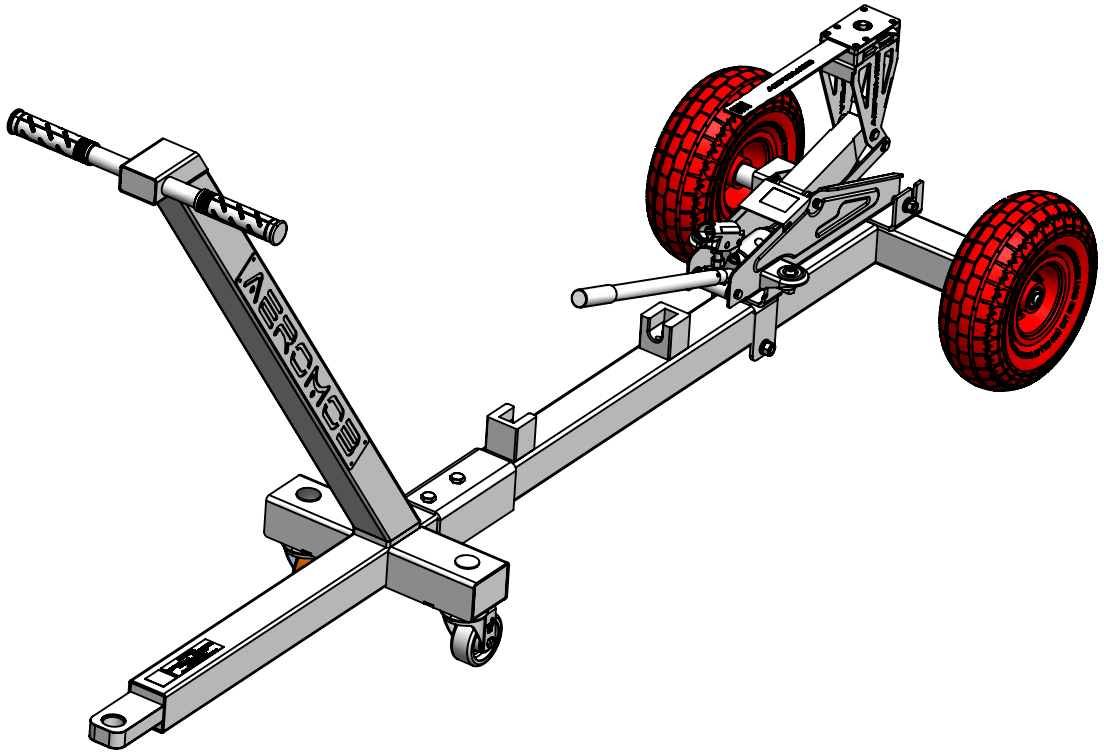

AEROMOB

POS.	ACTIVE PN	DESCRIPTION	QTY IN THIS DRAWING	QTY EQUIPMENT	OLD PN	APPLICABLE TO SN	AVAIL
1	ARO4	ALUMINIUM WHEEL 4"	1	2	ARO 4" V	ALL	---
2	CA 4 POL	AIR CHAMBER 4POL	1	2	---	ALL	---
3	PNEU 4.1/3.5/4	TYRE 4 POL	1	2	---	ALL	---
4	ROL 61804-2RS1	BALL BEARING 6804-2RS	2	4	---	ALL	---

CHAPTER 4 - ELEVATION SYSTEM

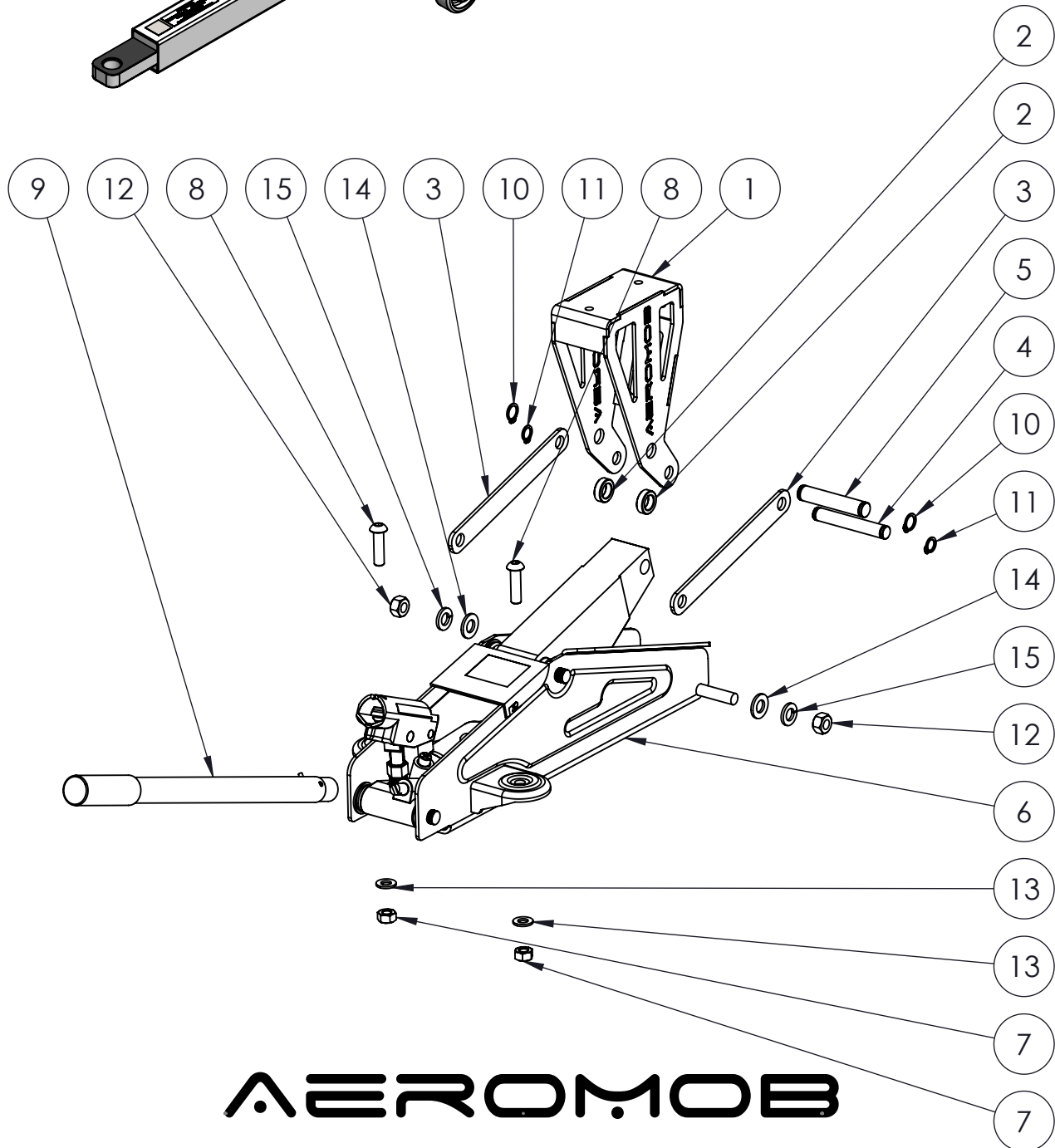
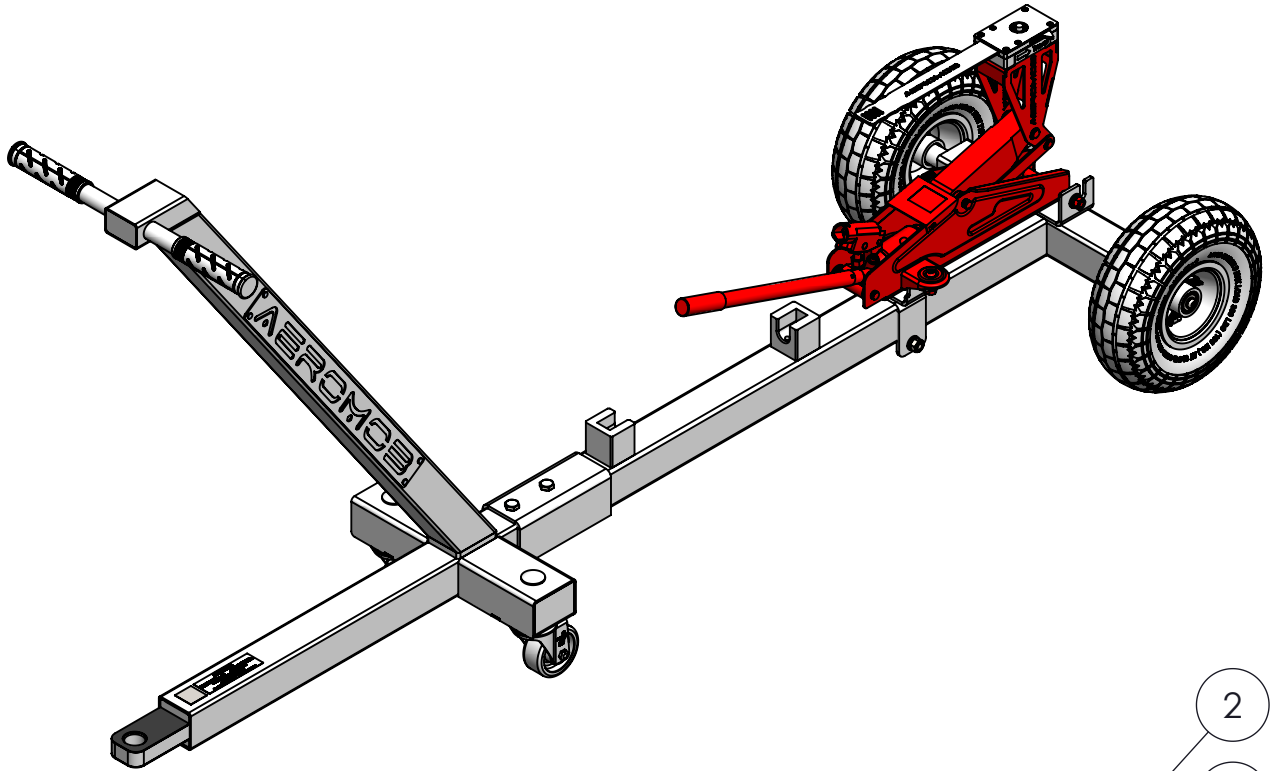

AEROMOB

POS.	ACTIVE PN	DESCRIPTION	QTY IN THIS DRAWING	QTY EQUIPMENT	OLD PN	APPLICABLE TO SN	AVAIL
1	AM-FRK-S04_V2	SUPPORT	1	1	FORK_S.04_V2	ALL	---
2	AM-FRK-029	BUSHING	2	2	FORK_29	ALL	---
3	AM-FRK-042	SHANK	2	2	FORK_42	ALL	---
4	AM-FRK-045	LOWER PIN	1	1	FORK_45	ALL	---
5	AM-FRK-046	HIGHER PIN	1	1	FORK_46	ALL	---
6	MH-2T	HYDRAULIC JACK 2T	1	1	-	ALL	---
7	DIN 934 M8	HEX NUT M8	2	2	---	ALL	---
8	DIN7380 M8X30	INT HEX BUTTON H SCREW M8 x 30	2	2	-	ALL	---
9	AM-FRK-66-S06	ASSY LEVER	1	1	-	ALL	---
10	ANEL EE18 - DIN471	SNAP RING 12mm	2	2	-	ALL	---
11	DIN471 ANEL10	SNAP RING 10mm	2	2	-	ALL	---
12	ASMEB1822 3/8	HEX NUT 3/8"	2	2	-	ALL	---
13	INOX DIN125 M8	WASHER M8	2	2	---	ALL	---
14	INOX DIN125 M10	WASHER M10	2	2	---	ALL	---
15	DIN 127-M18	LOCK WASHER M10	2	2	---	ALL	---

CHAPTER 5 - LOCK BOX

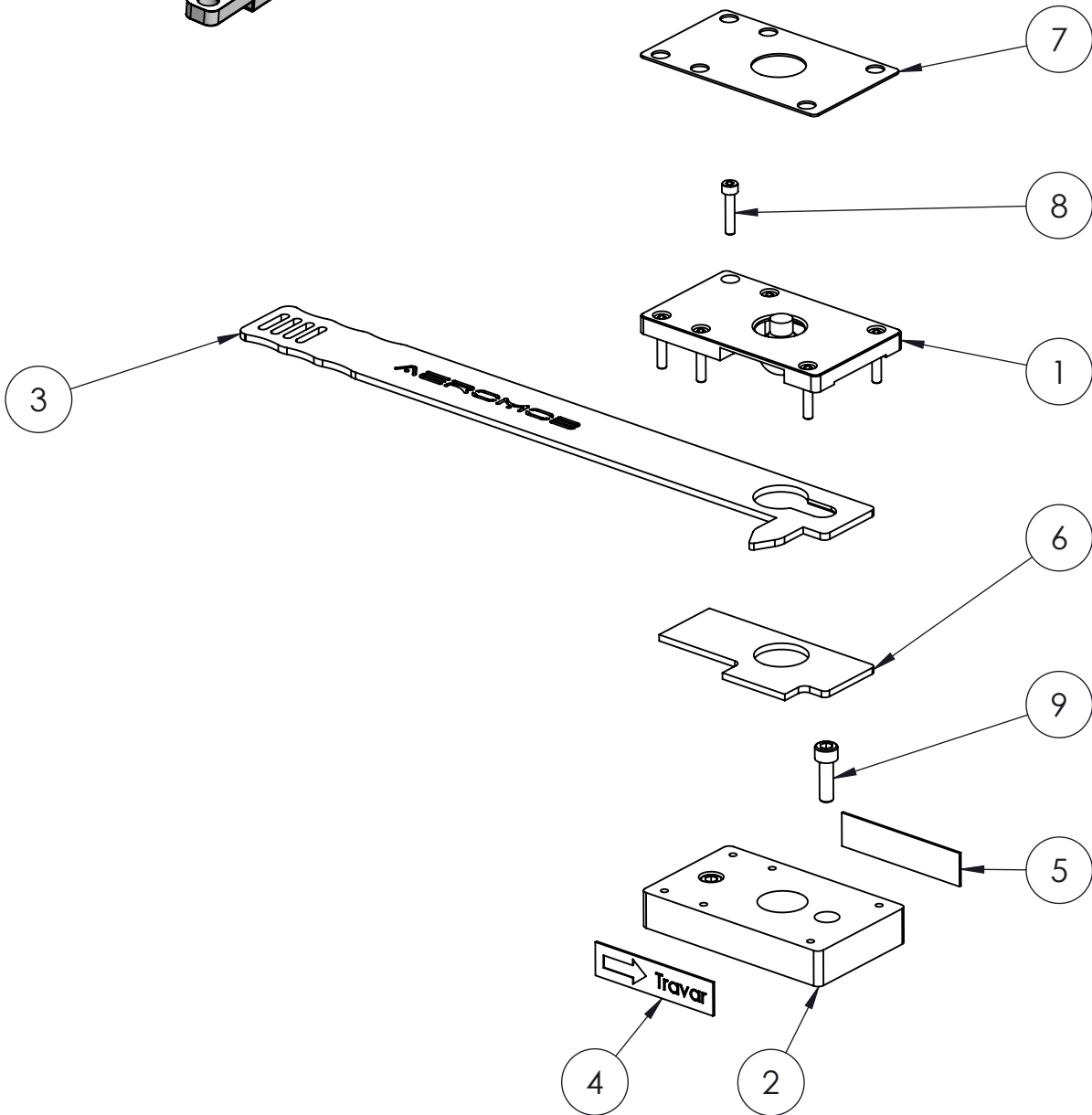
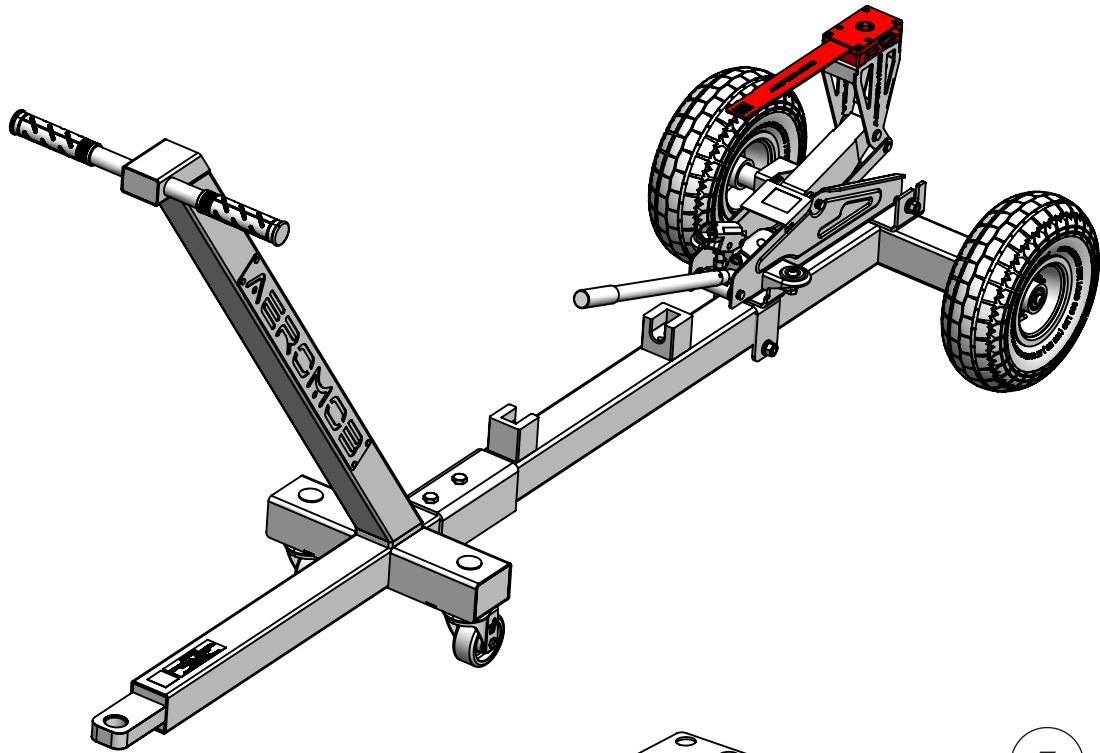

AEROMOB

POS.	ACTIVE PN	DESCRIPTION	QTY IN THIS DRAWING	QTY EQUIPMENT	OLD PN	APPLICABLE TO SN	AVAIL
1	AM-FRK-023	LID LOCKS HITCHING	1	1	FORK_23	ALL	---
2	AM-FRK-025	BASE LOCKS HITCHING	1	1	FORK_25	ALL	---
3	AM-FRK-026	LOCK PLATE	1	1	FORK_26	ALL	---
4	AM-FRK-034	ARROW LOCKS RIGHT	1	1	FORK_34	ALL	---
5	AM-FRK-035	ARROW LOCKS LEFT	1	1	FORK_35	ALL	---
6	AM-FRK-036	SLIDING PLATE	1	1	FORK_36	ALL	---
7	AM-FRK-040	PROTECTION OF LOCKBOX	1	1	FORK_40	ALL	---
8	DIN912 M4X20	INT HEX CIL HEAD SCREW M4 x 20	6	6	-----	ALL	---
9	DIN912 M6X20	INT HEX CIL HEAD SCREW M6 x 20	2	2	---	ALL	---