

STEP 1: ASSEMBLY OF CASTERS AND LOCKS

- Support the towing cart frame on 2 trestels, with the bottom facing up.
- Position the casters on the frame, in their respective positions.
- Insert the screws from bottom to top, as shown in image.
- Place the lock on the caster flange as shown in the image (DETAIL A).
- Tighten the caster screws.

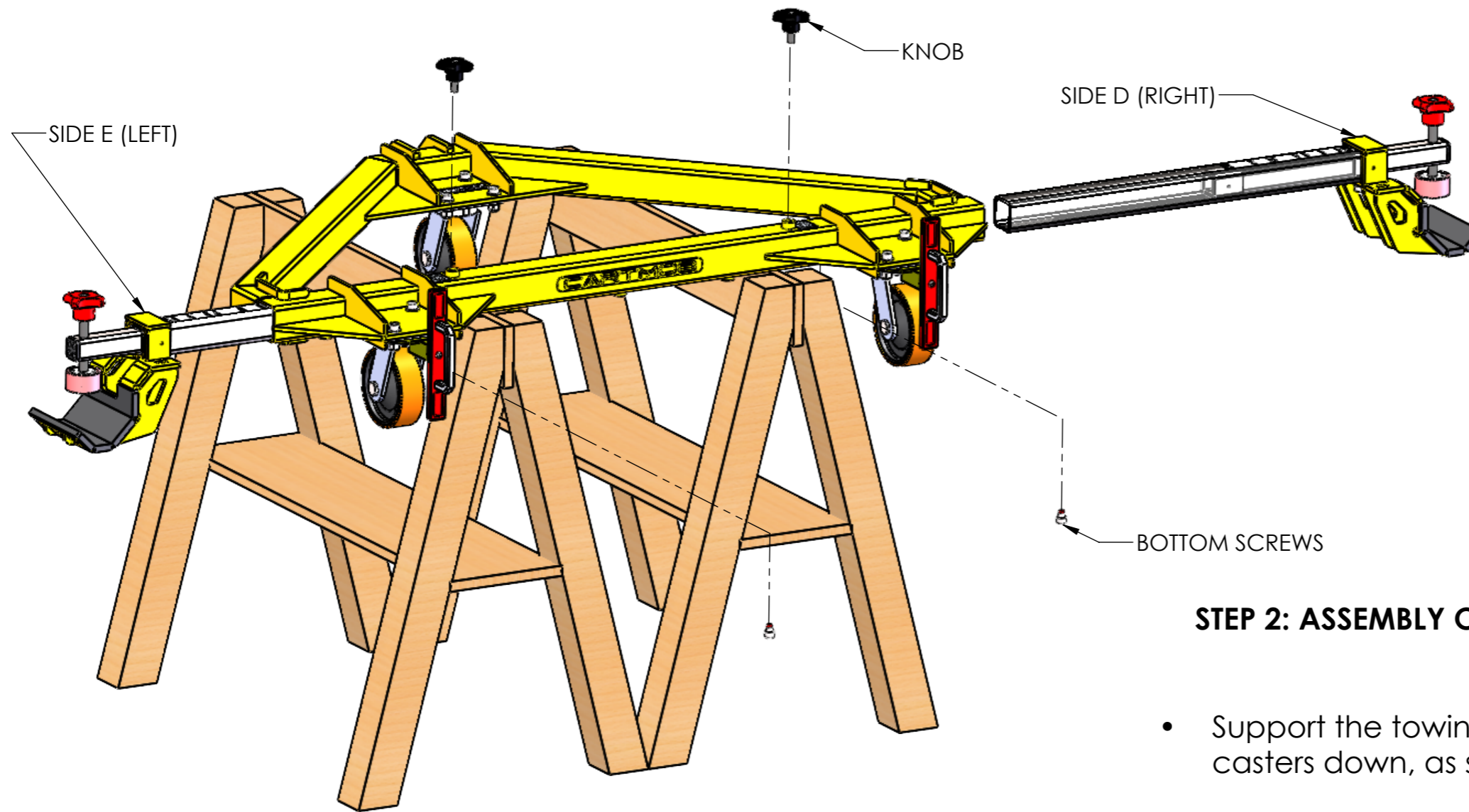

STEP 2: ASSEMBLY OF CLAW ARM

- Support the towing cart frame on 2 trestels, with the casters down, as shown on step 1.
- Place the claw arms in their respective sides, D and E, as shown in the image.
- Lock the claw arms using 2 knobs on the top and 2 screws on the bottom.

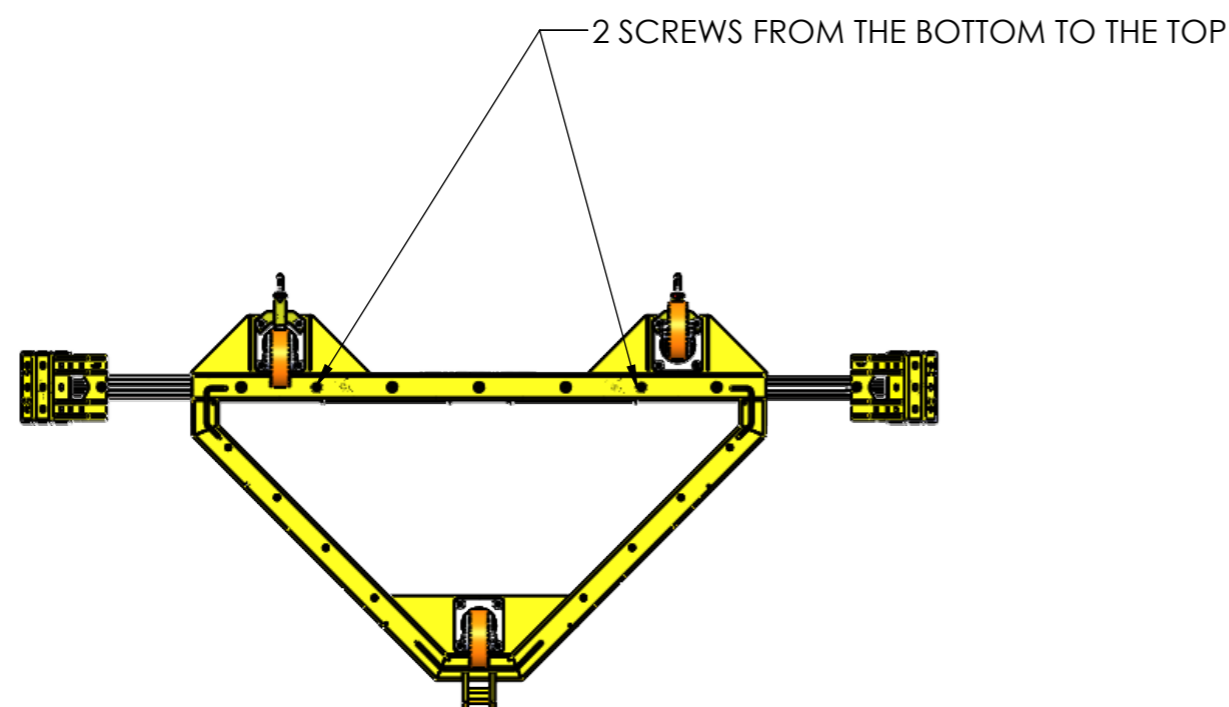

STEP 3: ASSEMBLY OF TOWBAR

- Remove the frame that is on the tresels and place over the floor.
- Unite the parts of the towbar using screws, washers and self-locking nuts, (DETAIL F).
- Unite the towbar to the equipment, according to DETAIL G. Apply thread lock glue on the pin screw.

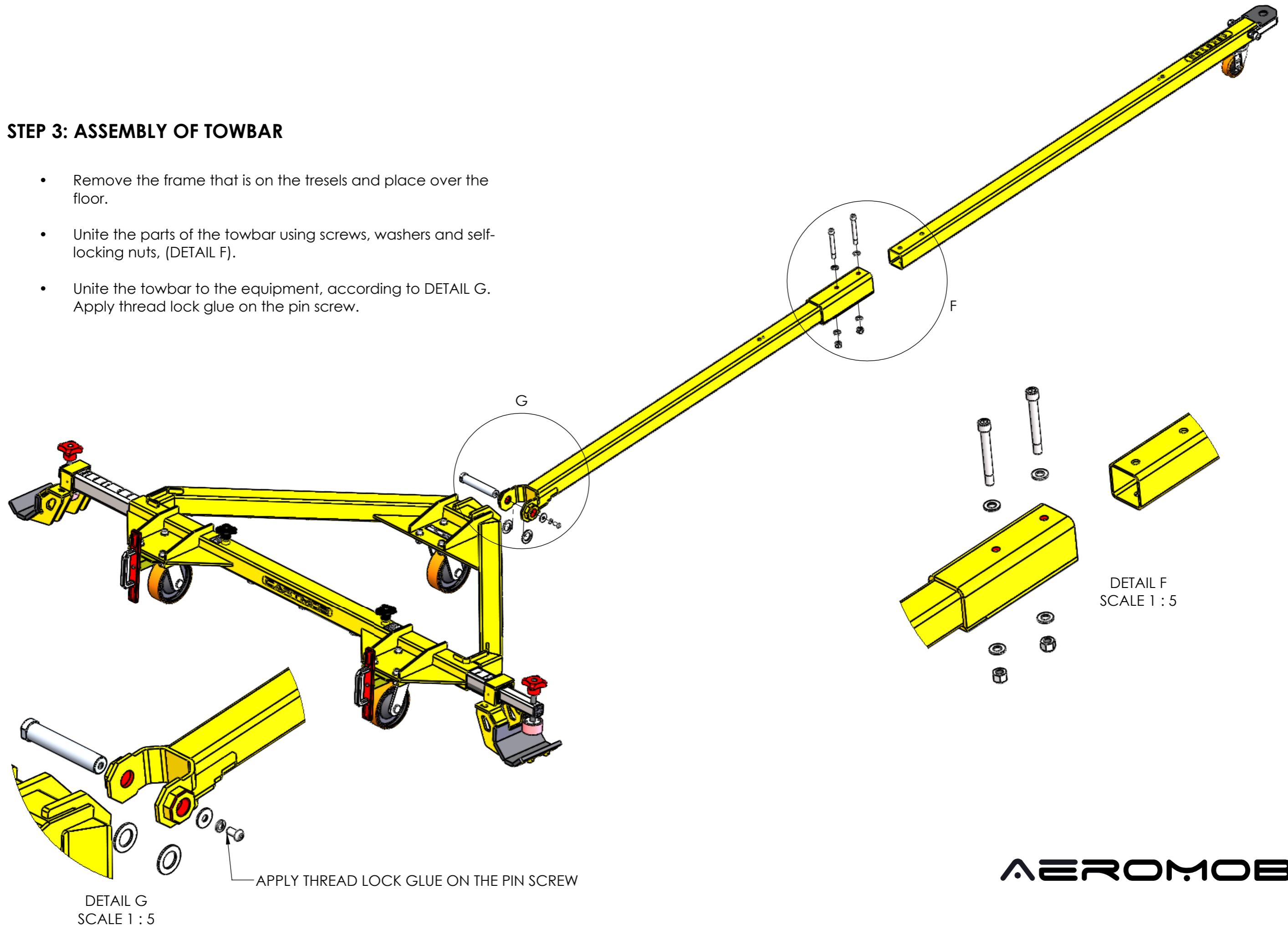

DETAIL G
SCALE 1 : 5

APPLY THREAD LOCK GLUE ON THE PIN SCREW

DETAIL F
SCALE 1 : 5

AEROMOB