

USE AND MAINTENANCE INSTRUCTIONS

EQUIPMENT MANUFACTURER: AEROMOB HELICOPTER PARTS INDUSTRY

EQUIPMENT NAME: AEROLADDER 429

EQUIPMENT DESCRIPTION: CARBON FIBER LADDER FOR ACCESSIBILITY OF PASSENGERS WITH REDUCED MOBILITY AND VIPs.

EQUIPMENT PART NUMBER: AM-LDR-429-K01

PART NUMBER: AM-LDR-429-K01 **AEROMOB**

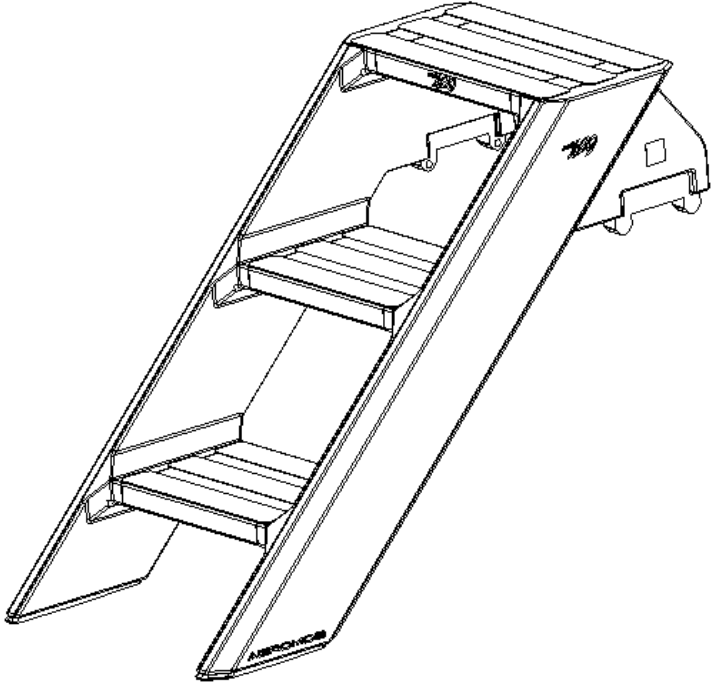

ITEMS OF THE PART NUMBER: AM-LDR-429-K01

ITEM NUMBER	DESCRIPTION	PART NUMBER	QTY
1	AEROLADDER 429	AM-LDR-429-M01	1

APPROVED USE

The equipment AEROLADDER 429, has the function of accessibility for helicopters passengers.

The AEROLADDER 429 is approved for use on Bell 429 helicopters in all versions, including landing gear.

The use of such equipment in other helicopter models or for functions not approved in this manual is expressly prohibited.

WARNING: It is mandatory to read this **FMS - FLIGHT MANUAL SUPPLEMENT** and have watched the **USER VIDEO MANUAL** completely before operating this equipment. If you have any questions, contact Aeromob technical support.

To access the updated version of this document, point your device at the QR CODE below.



www.aeromob.com.br/support-am-ldr-429-k01

BASIC TECHNICAL SPECIFICATIONS

- Monoblock construction in flameproof carbon fiber
- Total ladder weight: 6 lb / 2.8 kg

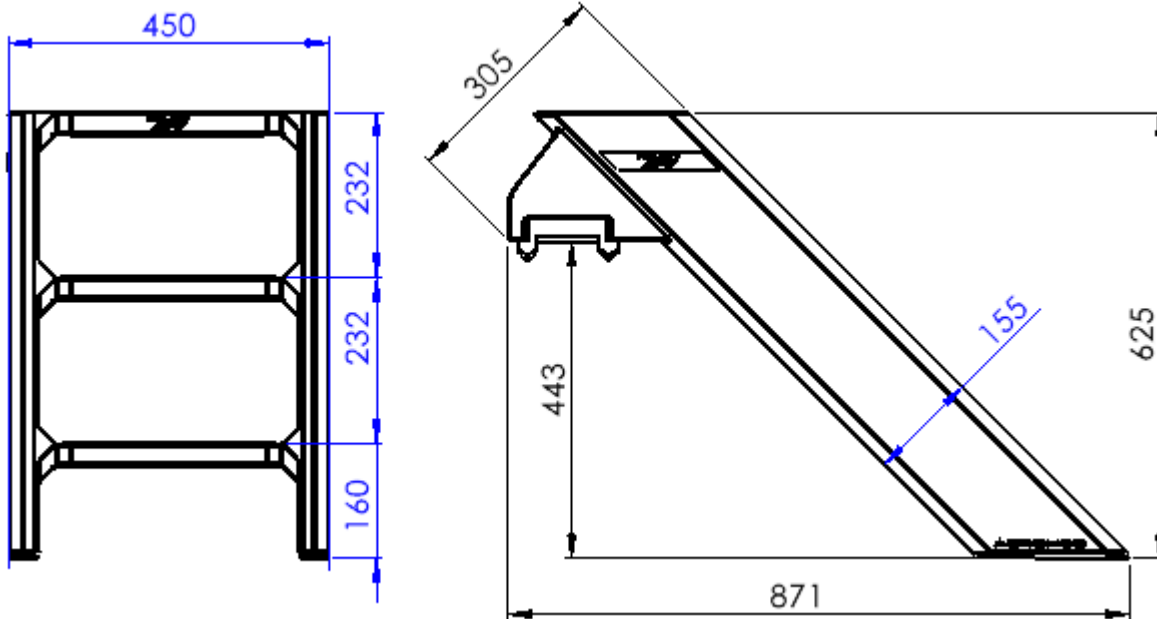

LIMITATIONS

- Approved for passengers up to 287lb / 130kg and using a maximum of 1 (one) passenger at a time for the exclusive use of boarding and disembarking.
- As for the type of surface approved, the AEROLADDER 429 can be used on paved floors, firm grass or firm beaten ground, being allowed the installation of the equipment in the aircraft on soils with up to 5% of inclination. Use on uneven terrain that leaves the ladder poorly supported is prohibited.
- Only the use of the equipment is allowed, being the complete set and in perfect operation. It is expressly prohibited and dangerous to use the equipment with any part, information board, missing component or using a component that is not part of this set and/ or has not been provided by the manufacturer. If any item or component needs to be replaced, contact the manufacturer.

BASIC DESCRIPTION OF USE

To use the ladder simply fit it completely in the Foot Step of the aircraft, aligned with the passenger exit door.

DANGER: Never use the ladder for boarding or disembarking without ensuring that the ladder is well fitted into the Foot Step.

REQUIRED MAINTENANCE

The revision plan and any necessary maintenance procedure must be carried out in accordance with the equipment maintenance manual (MM-AM-LDR-429-K01) to be accessed in the QR CODE available in this FMS.

WARRANTY

Your equipment has a 1 (year) warranty and, if necessary, it can be requested directly from AEROMOB through the link: www.aeromob-industry.com/support-am-ldr-429-k01.

RECOMMENDATIONS

- Highly important equipment for **Helicopters with Floats**, as it protects the floats against daily knocks when used as boarding and disembarking steps by passengers, which creates a high risk of hidden damage to the safety flotation system.
- If you have **SCT nº 2019S10-05 ANAC** applied, use the clamps fixed on the roof of the luggage compartment to better fix your ladder and so do not leave it loose between the luggage, which allows not to occupy useful space in the luggage compartment of the BELL 429 and leaves the ladder available as the first item after landing.